

POLE RATING (PER AASHTO 2013):
 3-SEC GUST WIND SPEED: 90 MPH MAX
 EPA (LUMINAIRE): 1.3 SQ. FT. MAX
 WEIGHT (LUMINAIRE): 55 LBS MAX

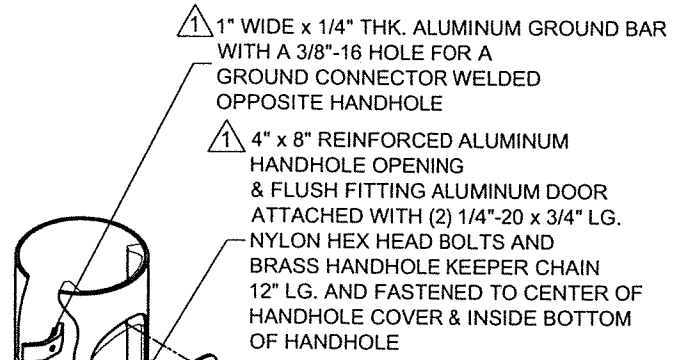

NOTE:
 3 7/16" x 6 3/32" MIN. DEBURRED CLEAR OPENING

DO NOT SCALE

TYPE OP301-6
 TYPE OP301-8



Valmont Industries, Inc. Structures Division
 20805 Eaton Ave Farmington, Minnesota 55024-7932
 Phone: (651) 463-8990 (800) 899-7577
 Fax: (651) 463-3349

TITLE: S TRANSFORMER BASE ALUMINUM POLE		QTY:
MODEL NO.: 270645706T4C		OWN BY: PVB
MATERIAL: ALUMINUM ALLOY		CHK'D BY:
FINISH: 100 GRIT SATIN POLISH		APPR BY: Mps
PROJECT: CITY OF OVERLAND PARK, KS		DATE: 09-22-17
SOLD TO: CITY OF OVERLAND PARK, KS		DWG NO: DSOP
SHIP TO:		PAGE:
P.O. NO:		BY: KPS
REP: POWER EQUIPMENT SALES		2 / 18

****CONFIDENTIAL****

The information contained in this drawing is privileged and confidential, and may be protected from disclosure. Please be aware that any use or dissemination of this drawing may be subject to legal restriction or sanction.

REV	DATE	REVISION DESCRIPTION	BY
1	04/06/18	UPDATED NOTES & J-HOOK SIZE	KPS