

OP POLE SERIES

DEVICE	DESCRIPTION	PROJ. AREA (FT ²)	WEIGHT (LBS)
(A)	12"-4 SEC. SIGNAL HEAD W/ BACK PLATES	12.00	54
(B)	12"-3 SEC. SIGNAL HEAD W/ BACK PLATES	10.00	42
(C)	12"-4 SEC. SIGNAL HEAD W/ NO BACK PLATES	6.00	40
(D)	16"x18"-1 SEC. PEDESTRIAN SIGNAL	3.00	20
(E)	36"x36" FLATSHEET ALUMINUM SIGN (MAX)	9.00	20
(F)	24"x96" ILLUMINATED STREET NAME SIGN (MAX)	16.00	120
(G)	ADVANCE RADAR DETECTOR	1.00	15
(H)	PRESENCE RADAR DETECTOR	1.00	15
(I)	CCTV CAMERA	1.00	15
(J)	LUMINAIRE	1.00	30
(K)	EMERGENCY VEHICLE PRE-EMPTION DETECTOR	0.50	5
(L)	36"x36" FLATSHEET ALUMINUM SIGN (MAX)	9.00	20

THE MAST ARM TRAFFIC STRUCTURES SHOWN ON THIS DRAWING HAVE BEEN DESIGNED IN ACCORDANCE WITH THE LOADING AND THE ALLOWABLE STRESS REQUIREMENTS OF THE 2013 AASHTO "STANDARDS SPECIFICATIONS FOR STRUCTURAL SUPPORTS FOR HIGHWAY SIGNS, LUMINAIRES AND TRAFFIC SIGNALS", SIXTH EDITION, LTS-6. THE WIND LOADS WERE CALCULATED FROM A BASIC WIND VELOCITY OF 90 MPH WITH A RECURRENCE INTERVAL OF 25 YEARS, AND A FATIGUE CATEGORY OF 2. THE FATIGUE LOADS WERE CALCULATED ON THE REQUIREMENTS OF SECTION 11 OF THE CODE, AND THE FOLLOWING DESIGN CONDITIONS.

- STRUCTURES ARE DESIGNED TO RESIST NATURAL WIND GUSTS BASED ON THE YEARLY MEAN WIND VELOCITY OF 11.2 MPH.
- STRUCTURES ARE NOT DESIGNED TO RESIST GALLOPING-INDUCED CYCLIC LOADS.
- TRUCK-INDUCED GUST LOADS ARE EXCLUDED PER THE REQUIREMENTS OF THE CODE

****NOTE:**
UPON INITIAL FIELD ASSEMBLY OF THE MAST-ARM'S FIRST SECTION'S BUTT PLATE TO THE MAST-ARM VERTICAL POLE'S BUTT PLATE, IF THE END USER DETERMINES THAT THERE IS A SUFFICIENT GAP AT A BOLT HOLE SUCH THAT THERE WILL NOT BE FACE-TO-FACE CONTACT BETWEEN THE TWO BUTT PLATES, THEN A WASHER SHALL BE INSERTED TO PROVIDE FACE-TO-FACE CONTACT BETWEEN THE TWO BUTT PLATES IN ACCORDANCE WITH SECTION 5.16 "BOLTED CONNECTIONS" OF THE 2013 EDITION OF AASHTO.

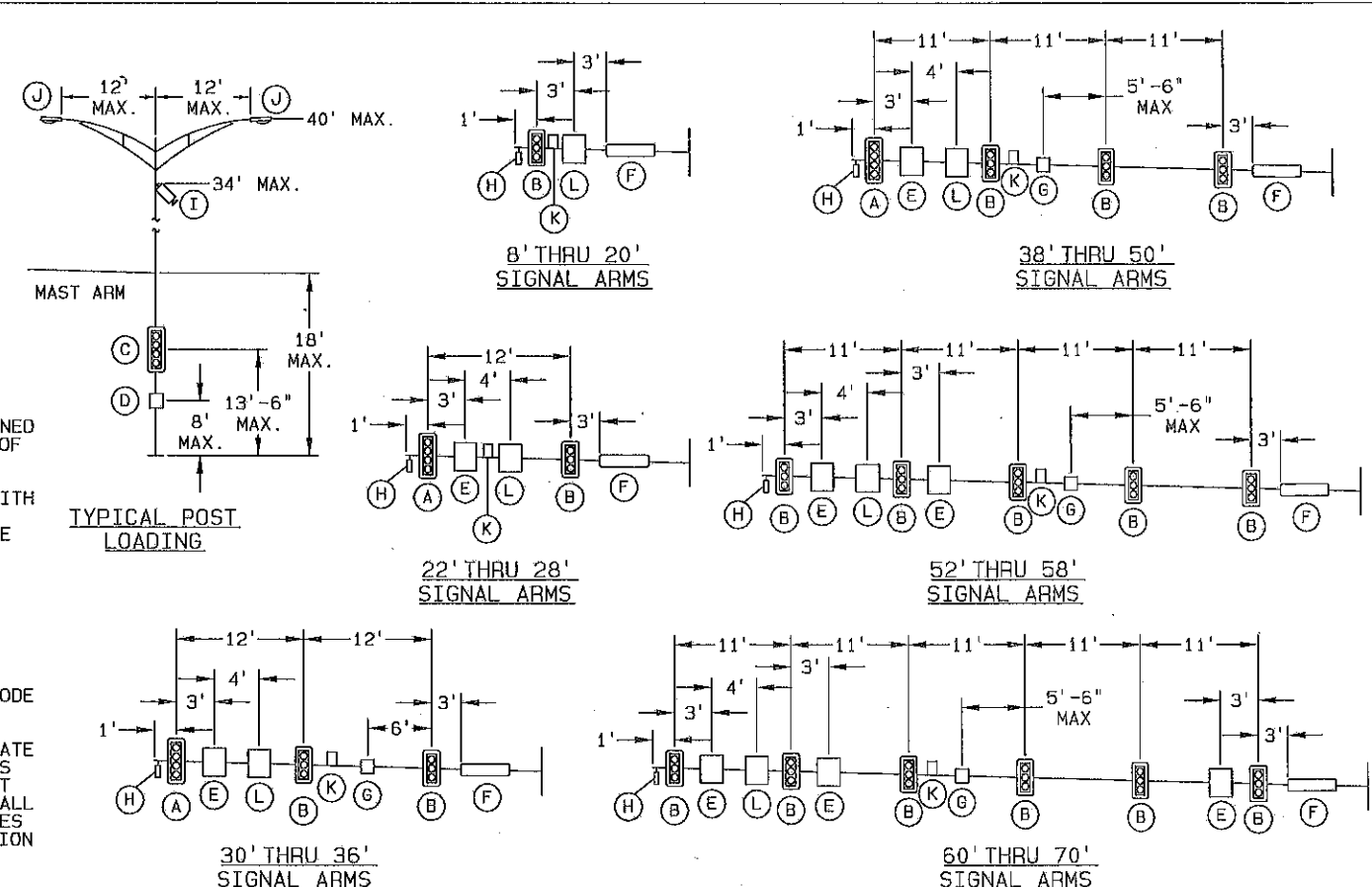

MAXIMUM LOADING INFORMATION

TABLE 1: POLE AND SIGNAL ARM DATA

POLE SERIES	SIGNAL ARM SPAN (FT)	DESIGNATION KEY				POLE DATA		BASE PLATE DATA					ANCHOR BOLT DATA				SIGNAL ARM DATA				SIGNAL ARM ATTACHMENT DATA						
		TYPE	LUMINAIRE ARM		BASE DIA. (IN)	LENGTH	WALL GAUGE OR THK.	SQUARE "S" (IN)	BOLT CIRCLE "Y" (IN)	THK. "M" (IN)	CENTER HOLE "P" (IN)	BOLT HOLE "Z" (IN)	DIA. "K" (IN)	LENGTH "J" (IN)	HOOK "H" (IN)	THREAD LENGTH "U" (IN)	BOLT QTY.	FIXED END DIA (IN)	FREE END DIA (IN)	GAUGE OF THK (IN)	SIGNAL ARM SPAN (FT)	SQUARE "A" (IN)	ARM & POLE PLATE THK. "D" (IN)	BOLT SIZE "N" (IN)	BOLT PATTERN "B" (IN)	CENTER HOLE "C" (IN)	
			STYLE	SPAN (FT)																							STYLE
OP	20	NL, LR, MR, HR	A OR B	6-12	A OR B	6-12	12.00	7	17.00	16.00	2.00	10.50	1.75	1.50	54.00	6.00	8.00	4	8.00	5.20	7	20.00	17.25	2.00	1.25 X 6.25	14.00	7.00
	22																										
	24	NL, LR, MR, HR	A OR B	6-12	A OR B	6-12	12.50	5	17.50	16.50	2.00	11.00	1.75	1.50	54.00	6.00	8.00	4	9.00	5.92	7	22.00	17.75	2.00	1.25 X 6.25	14.50	7.64
	26																										
	28																										
OP	30																										
	32	NL, LR, MR, HR	A OR B	6-12	A OR B	6-12	13.00	3	18.50	17.50	2.00	11.50	2.00	1.75	84.00	6.00	8.00	4	10.00	5.80	7	30.00	18.25	2.00	1.25 X 6.25	15.00	8.50
	34																										
	36																										
	38																										
OP	40																										
	42																										
	44	NL, LR, MR, HR	A OR B	6-12	A OR B	6-12	16.00	0.250	22.00	21.00	2.25	14.00	2.00	1.75	84.00	6.00	8.00	4	13.00	7.48	DET. 4	42.00	21.25	2.00	1.25 X 6.25	18.00	10.50
	46																										
	48																										
OP	50																										
	52																										
	54	NL, LR, MR, HR	A OR B	6-12	A OR B	6-12	17.00	0.250	23.00	22.00	2.25	14.75	2.25	2.00	84.00	6.00	10.00	4	14.00	7.08	DET. 4	52.00	23.25	2.50	1.50 X 7.50	19.50	11.75
	56																										
	58																										
OP	60																										
	62																										
	64	NL, LR, MR, HR	A OR B	6-12	A OR B	6-12	20.00	0.250	28.00	27.00	2.25	14.25	2.25	2.00	84.00	6.00	10.00	4	15.00	7.80	DET. 4	54.00	23.25	2.50	1.50 X 7.50	19.50	12.50
	66																										
	68																										
70																											

SEE TABLE 2

TABLE 2: ELEVATIONS

ELEVATIONS	TYPE			
	NO LUM (N/A)	LOW RISE (LR)	MEDIUM RISE (MR)	HIGH RISE (HR)
LUMINAIRE MOUNTING HEIGHT	N/A	30'-0"	35'-0"	40'-0"
POLE LENGTH	20'-6"	27'-0"	32'-0"	37'-0"

ALTHOUGH RARE, VIBRATIONS SEVERE ENOUGH TO CAUSE DAMAGE CAN OCCASIONALLY OCCUR IN STRUCTURES OF ALL TYPES. BECAUSE THEY ARE INFLUENCED BY MANY INTERACTING VARIABLES, VIBRATIONS ARE GENERALLY UNPREDICTABLE. THE USER'S MAINTENANCE PROGRAM SHOULD INCLUDE OBSERVATION FOR EXCESSIVE VIBRATION AND EXAMINATION FOR ANY STRUCTURAL DAMAGE OR BOLT LOOSENING. THE VALMONT WARRANTY SPECIFICALLY EXCLUDES FATIGUE FAILURE OR SIMILAR PHENOMENA RESULTING FROM INDUCED VIBRATION, HARMONIC OSCILLATION OR RESONANCE ASSOCIATED WITH MOVEMENT OF AIR CURRENTS AROUND THE PRODUCT.

VIBRATION DISCLAIMER

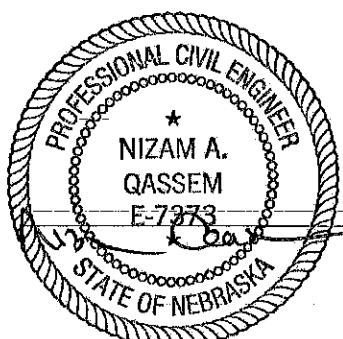

9-11-17

REV	DRAWN BY-DATE	CHECK BY-DATE	DESCRIPTION
F	BD4 09/08/17	BD4 09/08/17	ADDED ID TAG
E	KJW5 02/28/17	KJW5 02/28/17	REMOVED NUT COVERS
D	KJW5 11/28/16	BD4 12/02/16	REVISED HANDHOLE SIZES & WELD REIN
	JWK3 05/02/14	NKL 05/07/14	

TITLE CITY OF OVERLAND PARK, KANSAS
2013 AASHTO DESIGNS
TRAFFIC SIGNAL STRUCTURES

VALMONT INDUSTRIES, INC. RESERVES THE RIGHT TO INSTALL VARIOUS, ENGINEER APPROVED, MATERIAL HANGING ACCOMMODATIONS TO FACILITATE THE MANUFACTURING PROCESS.



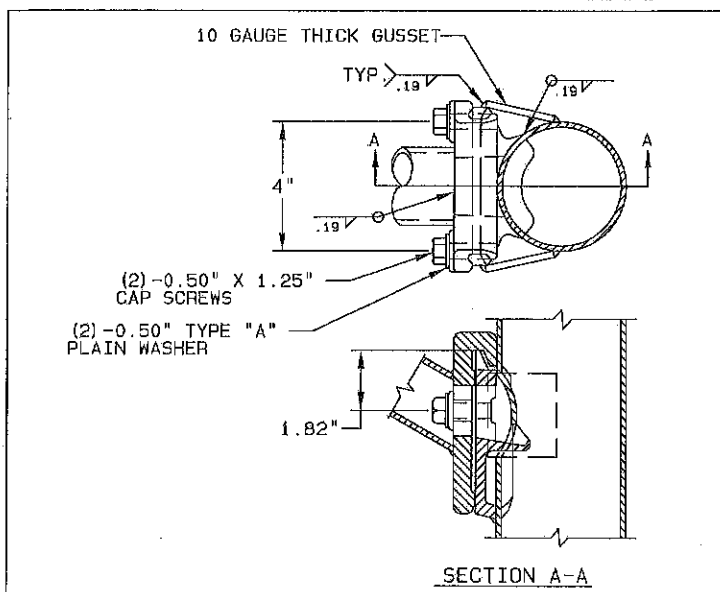
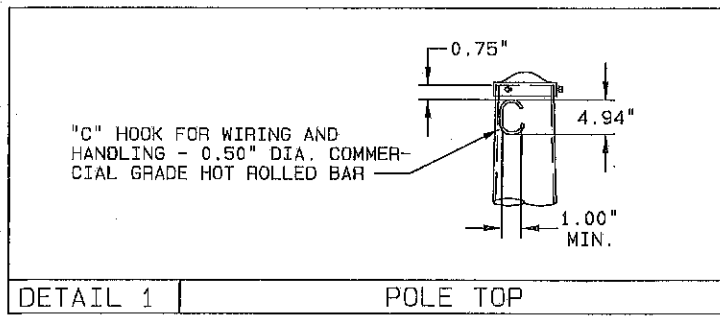

DETAIL 2 LUMINAIRE ARM ATTACHMENT

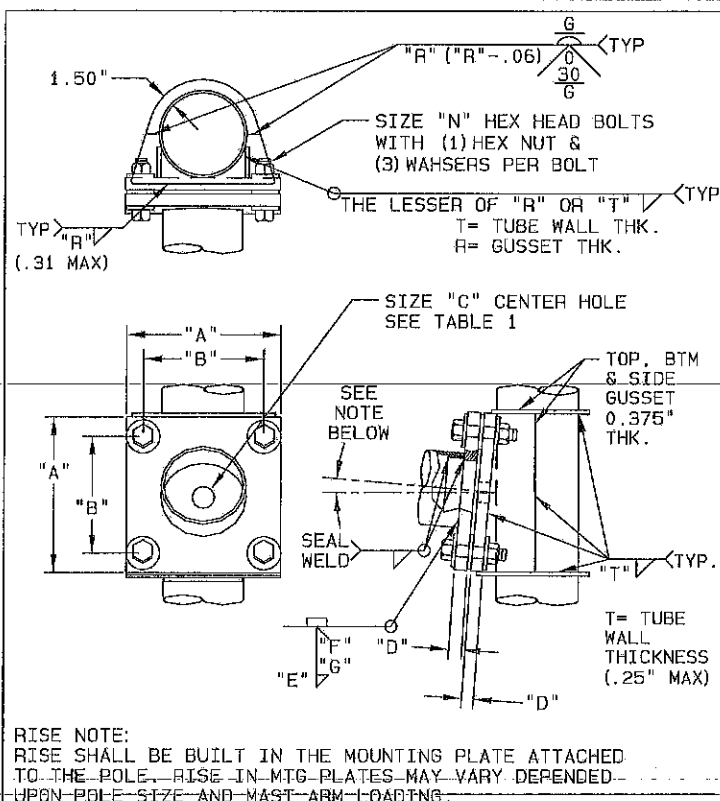

ARM SHAFT WALL THK.	ARM-TO-PLATE WELD "E"	BEVEL "F" X "G"
ALL	(ARM THK. + .25") X ARM THK.	.19" X 30°

DETAIL 3 SIGNAL ARM ATTACHMENT

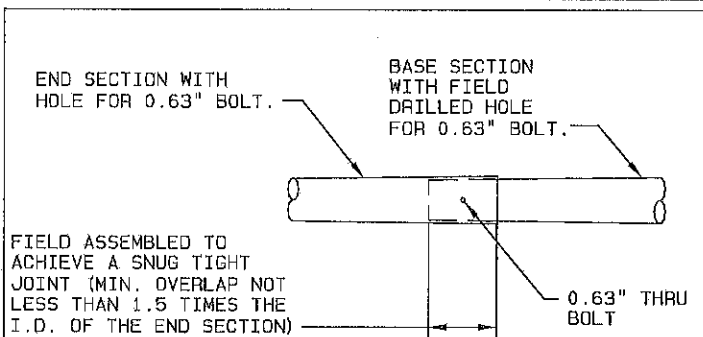

SPAN (FT)	BASE SECTION			END SECTION		
	LENGTH (FT)	GAUGE/THK (IN)	BASE DIA. (IN)	LENGTH (FT)	GAUGE/THK (IN)	
40.00	19.29	0.313	11.00	23.15	7	
42.00	19.29	0.313	11.00	25.15	7	
44.00	19.29	0.313	11.00	27.15	7	
46.00	26.43	0.313	11.00	22.01	7	
48.00	26.43	0.313	11.00	24.01	7	
50.00	15.97	0.313	13.00	36.72	7	
52.00	19.42	0.375	12.00	35.15	7	
54.00	19.54	0.375	13.00	37.15	7	
56.00	19.54	0.375	13.00	39.15	7	
58.00	23.11	0.375	13.00	37.58	7	
60.00	19.75	0.375	14.00	43.07	0.188	
62.00	19.83	0.375	14.50	45.05	0.188	
64.00	19.92	0.375	15.00	47.02	0.188	
66.00	27.00	0.375	14.50	41.88	0.188	
68.00	27.08	0.375	15.50	43.93	0.188	
70.00	27.08	0.375	15.50	45.93	0.188	

DETAIL 4 40'-70' SIGNAL ARM SLIP JOINT

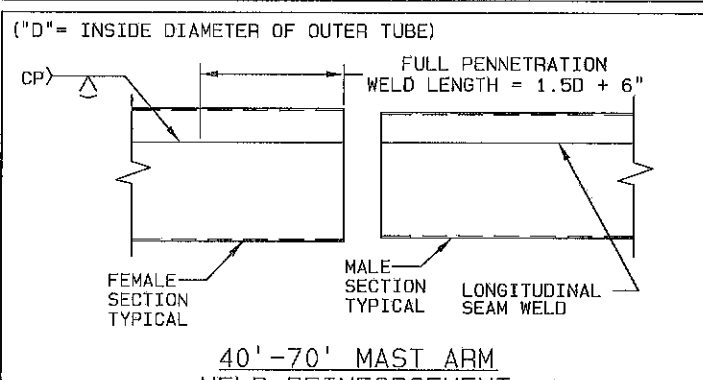

DETAIL 5 MAST ARM WELD REINFORCEMENT

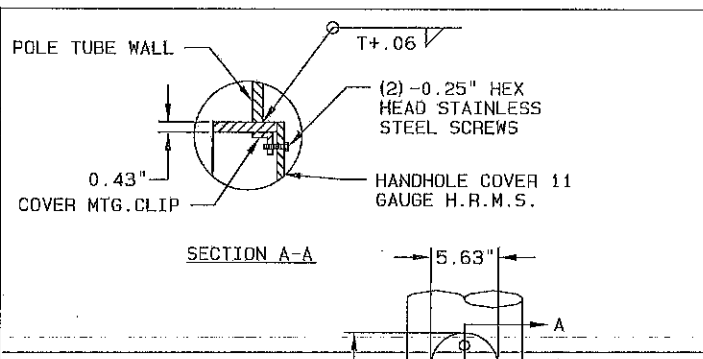

DETAIL 6 UPPER HANDHOLE

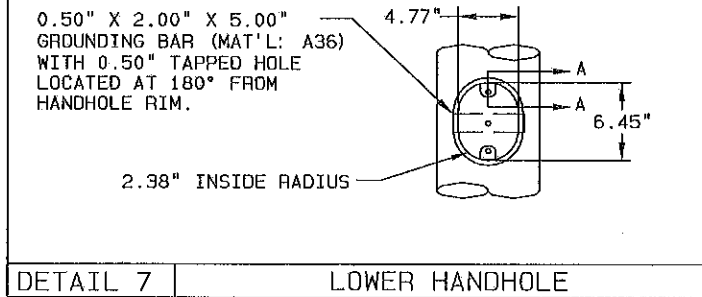
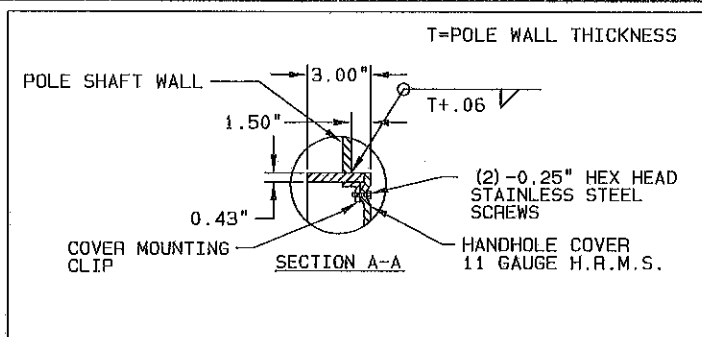

DETAIL 7 LOWER HANDHOLE

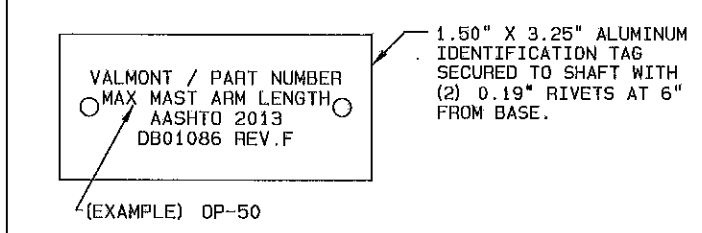

DETAIL 8 I.D. TAG

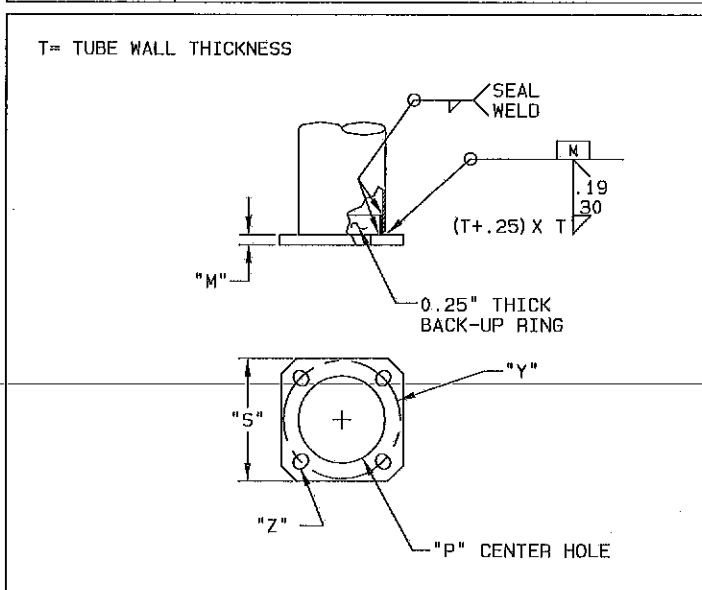

DETAIL 9 POLE BASE

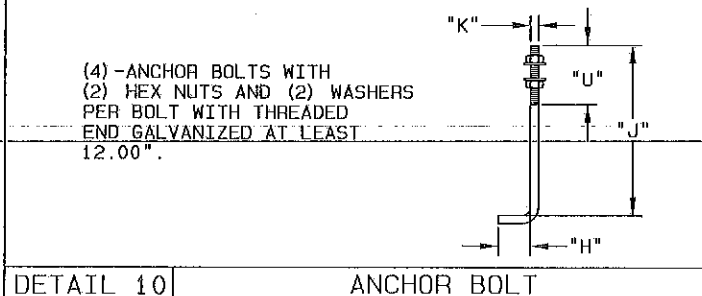

DETAIL 10 ANCHOR BOLT

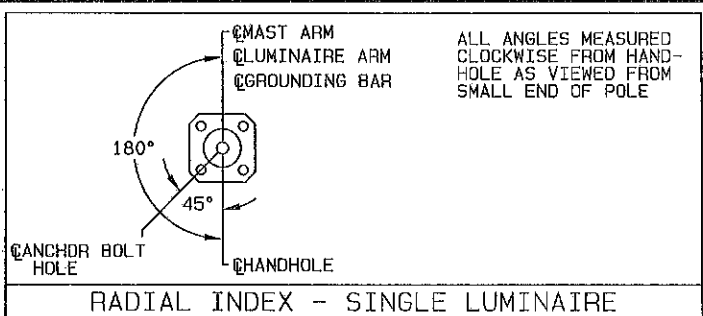

RADIAL INDEX - SINGLE LUMINAIRE

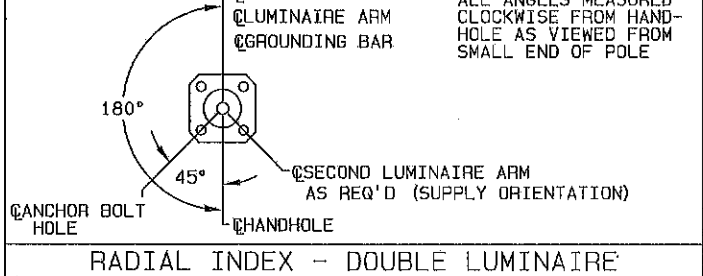

RADIAL INDEX - DOUBLE LUMINAIRE

TABLE 3: MATERIAL DATA

COMPONENT	ASTM DESIGNATION	MIN. YIELD (KSI)
ALL TAPERED SHAFTS	A595 GR. A OR A572	55
BASE PLATE	A572 GR. 50	50
SIMPLEX PLATE	A572 GR. 50	50
LUM ARM ATTACHMENT	A27 GR. 65-35 OR A36	35
LUMINAIRE ARM - 2" SCHEDULE 40 PIPE	ASTM A501, A513, A618 OR A500 GR. B	36
LUMINAIRE CONN. BOLTS	SAE GR. 5	--
ANCHOR BOLTS	F1554 GR. 55	55
ARM CONNECTING HARDWARE	A325	--
GALVANIZING-HARDWARE	HOT DIP ZINC	--

FINISH DATA

STANDARD FINISH	OPTIONAL FINISH
SYSTEM: GALVANIZED (GV)	SYSTEM: FINISH PAINT/GALVANIZED (FPGV)
BASE COAT: HOT-DIP GALV. TO ASTM A123	BASE COAT: HOT-DIP GALVANIZED TO ASTM A123
PRIME COAT: NONE	PRIME COAT: NONE
FINISH COAT: NONE	FINISH COAT: TGIC OR URETHANE POLYESTER POWDER
COLOR: NONE	COLOR: ?????
SPEC: F-1	SPEC: F-283????

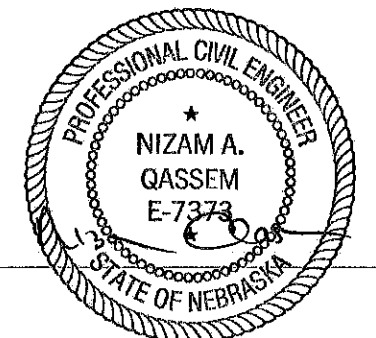

9-11-17