

NOTE: 6'-0" AND 8'-0" LUMINAIRE ARMS CAN BE SUPPLIED AS STYLE A OR B. LUMINAIRE ARMS LONGER THAN 8'-0" MUST BE STYLE B.

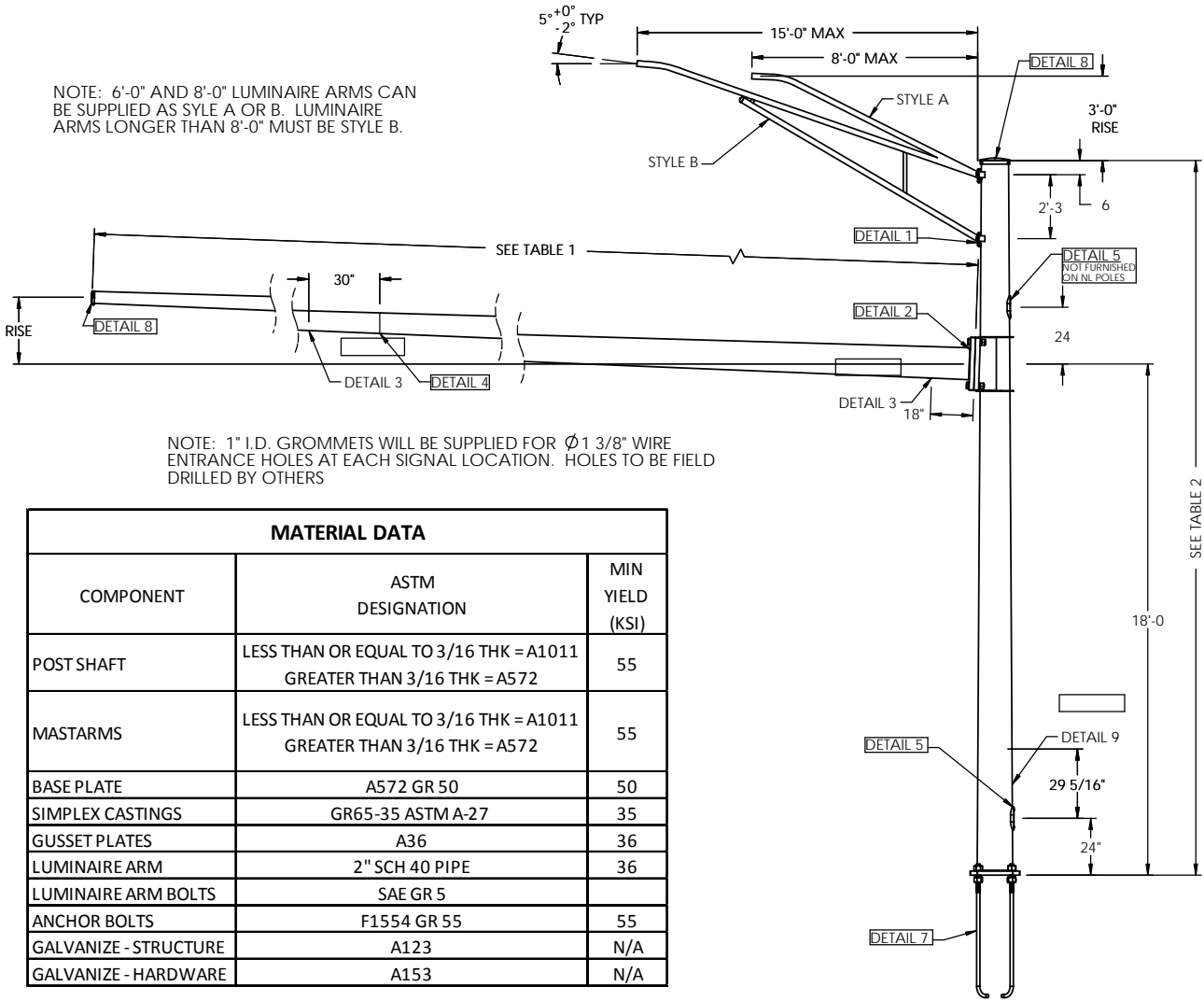

NOTE: 1" I.D. GROMMETS WILL BE SUPPLIED FOR Ø1 3/8" WIRE ENTRANCE HOLES AT EACH SIGNAL LOCATION. HOLES TO BE FIELD DRILLED BY OTHERS

MATERIAL DATA		
COMPONENT	ASTM DESIGNATION	MIN YIELD (KSI)
POST SHAFT	LESS THAN OR EQUAL TO 3/16 THK = A1011 GREATER THAN 3/16 THK = A572	55
MASTARMS	LESS THAN OR EQUAL TO 3/16 THK = A1011 GREATER THAN 3/16 THK = A572	55
BASE PLATE	A572 GR 50	50
SIMPLEX CASTINGS	GR65-35 ASTM A-27	35
GUSSET PLATES	A36	36
LUMINAIRE ARM	2" SCH 40 PIPE	36
LUMINAIRE ARM BOLTS	SAE GR 5	
ANCHOR BOLTS	F1554 GR 55	55
GALVANIZE - STRUCTURE	A123	N/A
GALVANIZE - HARDWARE	A153	N/A

NOTE:

- THE MASTARM TRAFFIC STRUCTURES SHOWN ON THIS DRAWING HAVE BEEN DESIGNED IN ACCORDANCE WITH THE LOADING AND THE ALLOWABLE STRESS REQUIREMENTS OF THE 2013 AASHTO "STANDARDS SPECIFICATIONS FOR STRUCTURAL SUPPORTS FOR HIGHWAY SIGNS, LUMINAIRES AND TRAFFIC SIGNALS", SIXTH EDITION, LTS-6. THE WIND LOADS WERE CALCULATED FROM A BASIC WIND VELOCITY OF 90 MPH WITH A RECURRENCE INTERVAL OF 25 YEARS, AND A FATIGUE CATEGORY OF 2. THE FATIGUE LOADS WERE CALCULATED ON THE REQUIREMENTS OF SECTION 11 OF THE CODE, AND THE FOLLOWING DESIGN CONDITIONS:

- STRUCTURES ARE DESIGNED TO RESIST NATURAL WIND GUSTS BASED ON THE YEARLY MEAN WIND VELOCITY OF 11.2 MPH
- STRUCTURES ARE NOT DESIGNED TO RESIST GALLOPING - INDUCED CYCLIC LOADS
- TRUCK - INDUCED GUST LOADS ARE EXCLUDED PER THE REQUIREMENTS OF THE CODE

- WELD PENETRATION - SHAFT TO BE ROUND TAPERED TUBE FABRICATED WITH ONE SUBMERGED ARC LONGITUDINAL SEAM WELD WITH 100% COMPLETE JOINT PENETRATION (CJP) WELD 6" FROM CIRCUMFRENENTIAL WELD AND 60% FOR REMAINDER. GAS METAL ARC WELDING PROCESS TO BE USED FOR REMAINDER OF WELDED FABRICATION WITH 100% COMPLETE JOINT PENETRATION (CJP) CIRCUMFRENENTIAL WELD FOR SHAFT TO BASE PLATE.

- WELD TESTING:
 - 100% OF ALL WELDS VISUAL TESTED (VT)
 - 100% OF ALL COMPLETE JOINT PENETRATION (CJP) WELDS ULTRASONIC TESTED (UT)
 - A RANDOM 30% OF ALL FILLET WELDS & PARTIAL JOINT PENETRATION (PJP) LONGITUDINAL SEAM WELDS MAGNETIC PARTICLE TESTED (MT)

- WELDING PER AWS D1.1 LATEST EDITION

- FOR MASTARMS USING SECTION DESIGN (NOMINALLY >50'), THE OVERLAP WILL BE AT LEAST 150% OF THE MAXIMUM DIAMETER OF THE OVERLAPPING SECTION (NOMINALLY 2'-0" OVERLAP). SECTIONS WILL BE "DRY" FIT IN FACTORY TO ENSURE MINIMUM OVERLAP IS ACHIEVED.

- VIBRATION DISCLAIMER: ALTHOUGH RARE, VIBRATIONS SEVERE ENOUGH TO CAUSE DAMAGE CAN OCCASIONALLY OCCUR IN STRUCTURES OF ALL TYPES. BECAUSE THEY ARE INFLUENCED BY MANY INTERACTING VARIABLES, VIBRATIONS ARE GENERALLY UNPREDICTABLE. THE USER'S MAINTENANCE PROGRAM SHOULD INCLUDE OBSERVATION FOR EXCESSIVE VIBRATION AND EXAMINATION FOR ANY STRUCTURAL DAMAGE OR BOLT LOOSENING.

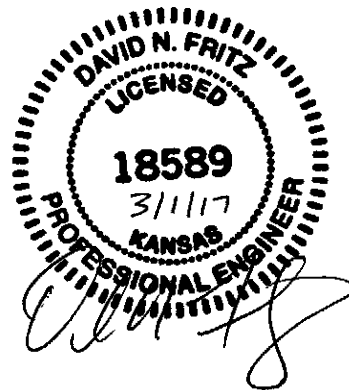

DESIGN LOAD CHART			
DEVICE	DESCRIPTION	PROJ AREA (SQ FT)	WEIGHT (LBS)
(A)	12"-4 SEC. SIGNAL HEAD W/BACK PLATES	12.00	54
(B)	12"-3 SEC. SIGNAL HEAD W/BACK PLATES	10.00	42
(C)	12"-4 SEC. SIGNAL HEAD W/ NO BACK PLATES	6.00	40
(D)	16"x18" 1-SEC PEDESTRIAN SIGNAL	3.00	20
(E)	36"x36" FLATSHEET ALUMINUM SIGN (MAX)	9.00	20
(F)	24"x96" ILLUMINATED STREET NAME SIGN (MAX)	16.00	120
(G)	ADVANCE RADAR DETECTOR	1.00	15
(H)	PRESENCE RADAR DETECTOR	1.00	15
(I)	CCTV CAMERA	1.00	15
(J)	LUMINAIRE	1.00	30
(K)	EMERGENCY VEHICLE PRE-EMPTION DETECTOR	0.50	5
(L)	36"x36" FLATSHEET ALUMINUM SIGN (MAX)	9.00	20

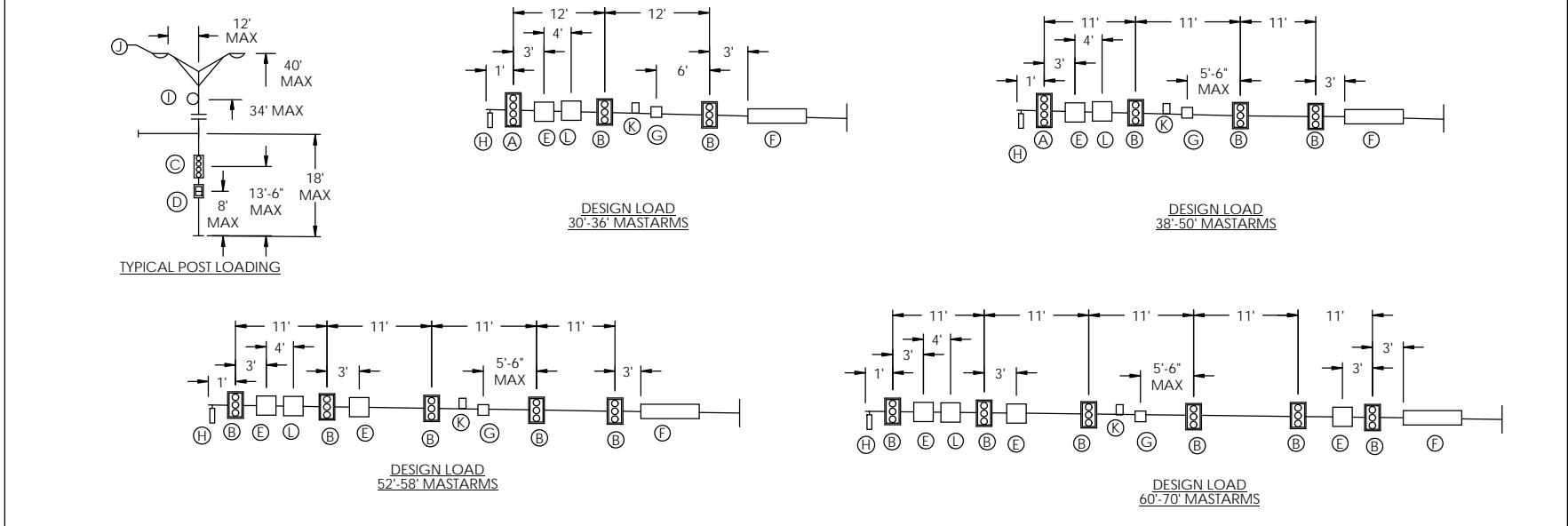

- NOTES:
- REV 11-03-14 ADDED ID TAGS TO POST AND MASTARM.
 - REV 7-30-15 ADDED 55'-0" ARM TO TABLE. (JEFF A)
 - REV 2-28-17: REMOVED NUT COVERS (DETAIL 6) REBEKAH

REVISIONS			
REV.	DESCRIPTION	DATE	DRAFTER
A	MULTIPLE CHANGES ON ALL 3 SHEETS PER SUTOMER REQUEST	10/3/2014	RLK
B	UPDATED SHEET 3 CHART LUM SIZES AND ADDED 19'6" POLE TO CHART FOR ARMS 52'0" AND GREATER	9/15/2016	JA
C	REMOVED NUT COVERS (DETAIL 6)	2/28/2017	RK

THIS DOCUMENT CONTAINS CONFIDENTIAL INFORMATION AND IS THE PROPERTY OF MILLERBERND MFG AND MAY NOT BE COPIED, REPRODUCED OR DISCLOSED IN ANY MANNER WITHOUT THE EXPRESS WRITTEN CONSENT FROM MILLERBERND MFG					
PROJECT:		MILLERBERND 622 6TH ST. SO. WINSTED, MN 55395			
DWN: REBEKAH	DATE: 07-29-14				
CHK BY: DOUG F.	DATE: 8/1/14	DESCRIPTION: ROUND TRAFFIC SIGNAL STANDARD OVERLAND PARK, KS 2013 AASHTO			
MATERIAL:					
WEIGHT:	SCALE: NTS	SHT-SIZE: B	DRWG NO.: 780B1885	SHEET: 1 OF 3	REV LEVEL: C

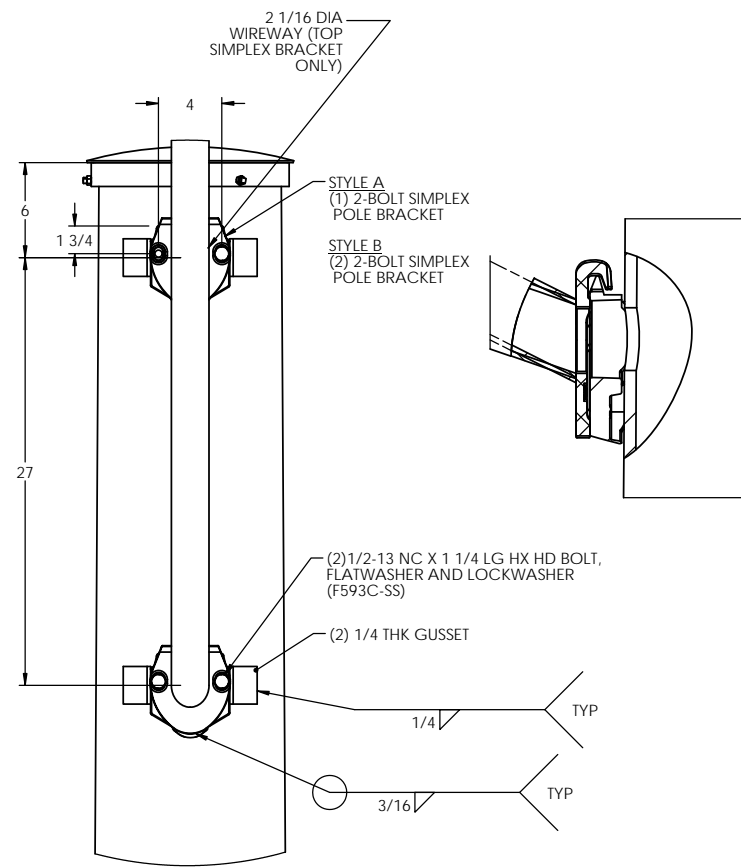

DETAIL 1 - LUMINAIRE ARM ATTACHMENT

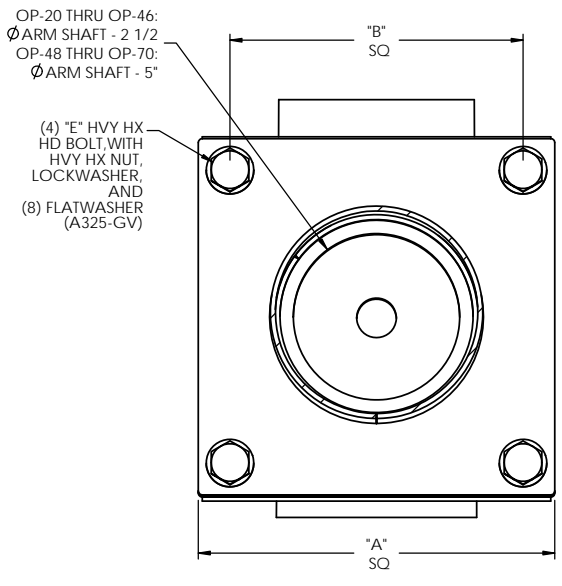

SECTION B-B

RISE NOTE:
RISE SHALL BE BUILT INTO THE MOUNTING PLATE ATTACHED TO THE POST. RISE IN MTG PLATES MAY VARY DEPENDING ON POLE SIZE AND MASTARM LOADING.

DETAIL 2 - MASTARM ATTACHMENT

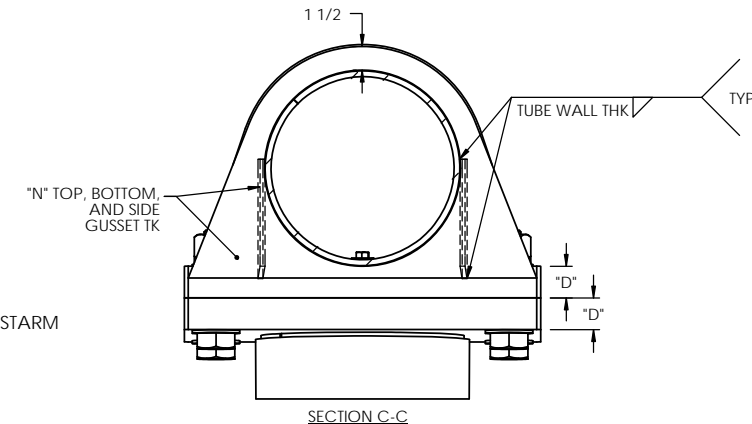

SECTION C-C

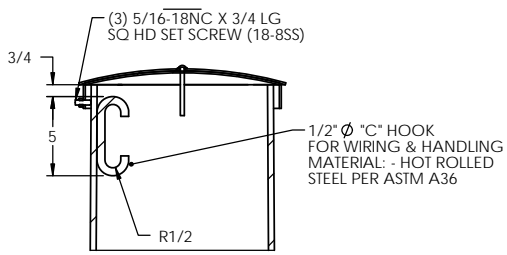
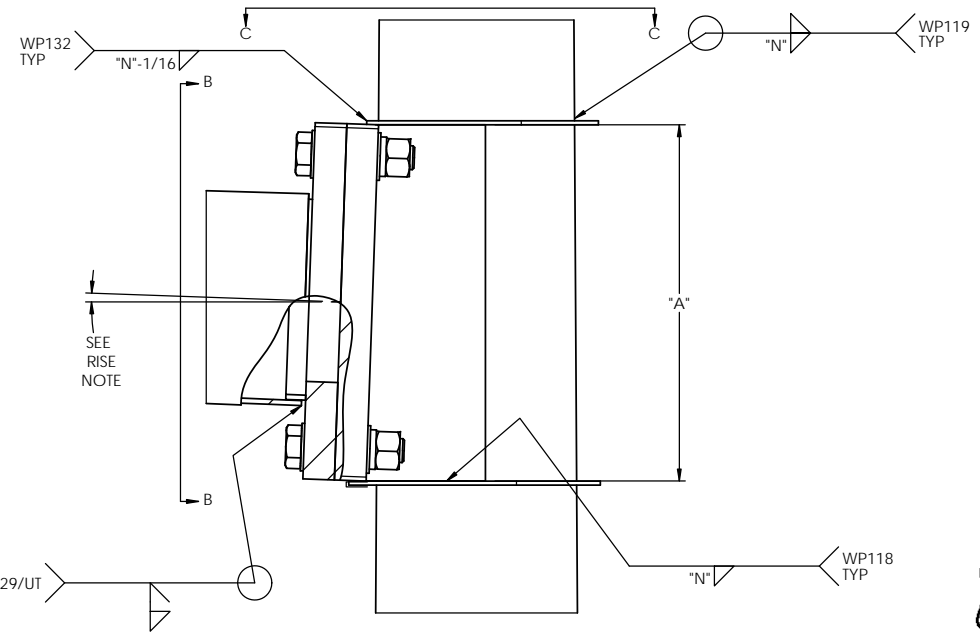

DETAIL 8 - END CAPS & POLE TOP

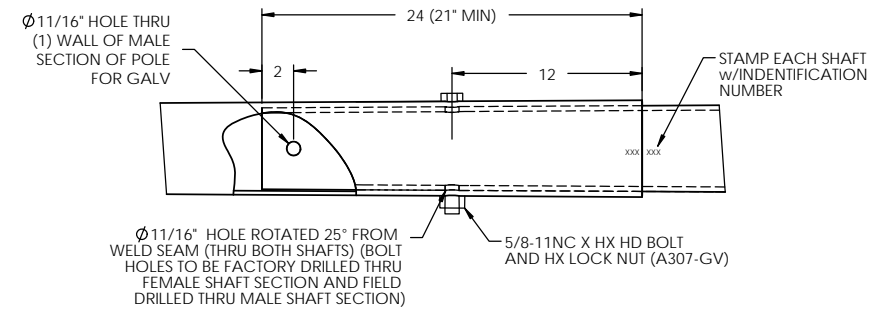

DETAIL 4 - MASTARM SPLICE

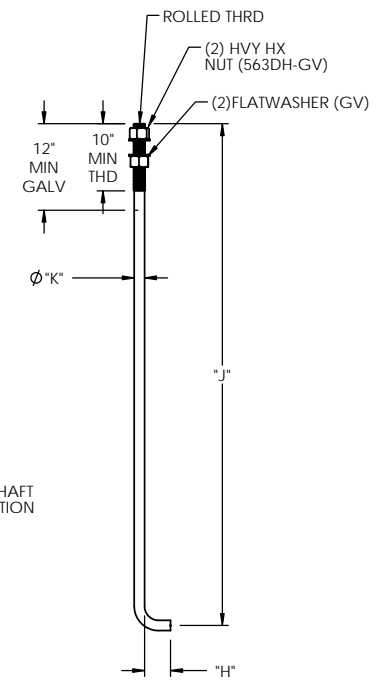

DETAIL 7 - ANCHOR BOLT DETAIL

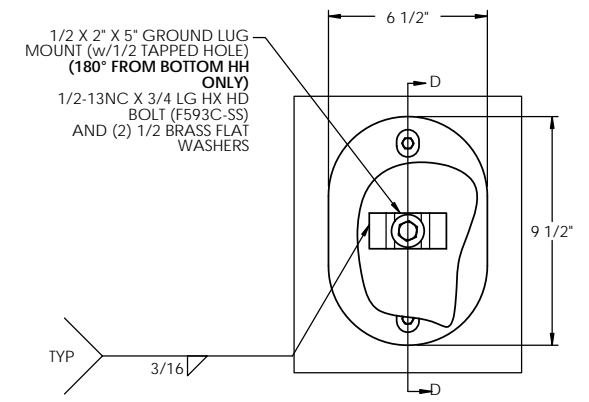

DETAIL 5 - M34 (5 X 8) HANDHOLE

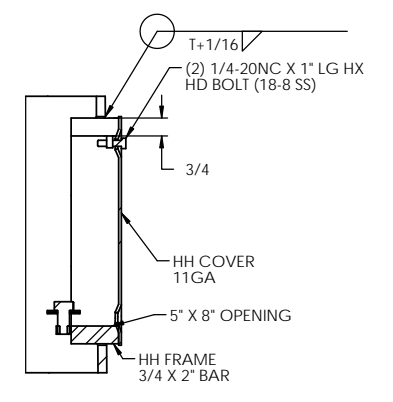

SECTION D-D

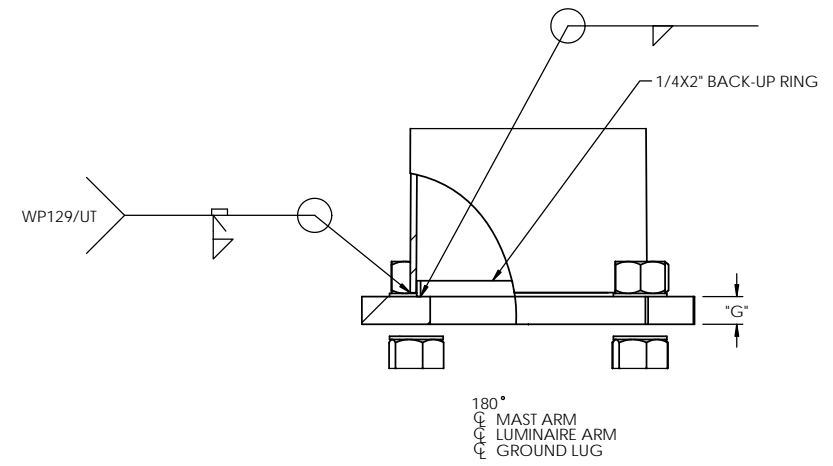

DETAIL 6 - POST BASE AND ATTACHMENT

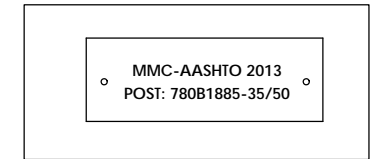
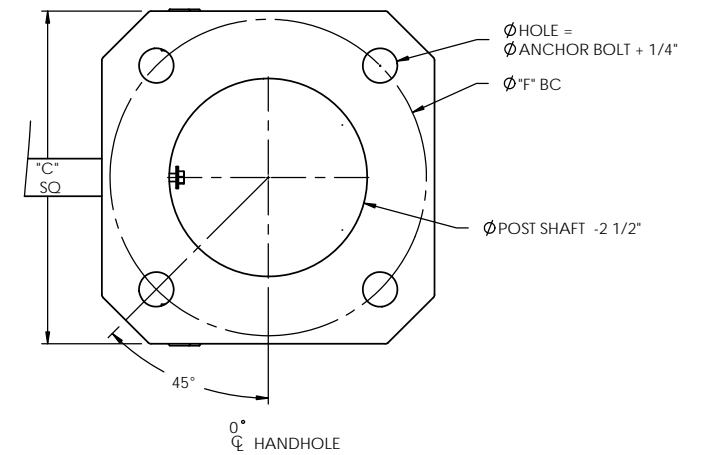

DETAIL 9 - POST ID TAG EXAMPLE DETAIL

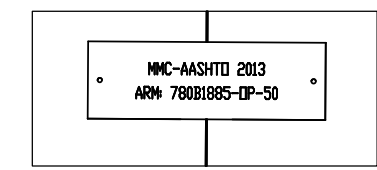

DETAIL 3 - MASTARM ID TAG EXAMPLE DETAIL

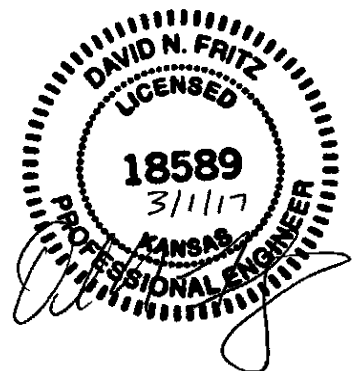

THIS DOCUMENT CONTAINS CONFIDENTIAL INFORMATION AND IS THE PROPERTY OF MILLERBERND MFG AND MAY NOT BE COPIED, REPRODUCED OR DISCLOSED IN ANY MANNER WITHOUT THE EXPRESS WRITTEN CONSENT FROM MILLERBERND MFG					
PROJECT:		MILLERBERND 622 6TH ST. SO. WINSTED, MN 55395			
DWN: REBEKAH	DATE: 07-29-14				
CHK BY: DOUG F.	DATE: 8/1/14	DESCRIPTION: ROUND TRAFFIC SIGNAL STANDARD OVERLAND PARK, KS 2013 AASHTO			
WEIGHT:	SCALE: NTS	SHT-SIZE: B	DRWG NO.: 780B1885	SHEET: 2 OF 3	REV LEVEL: B

MASTARM SPAN (FT)	TYPE	ARM 1		ARM 2		BASE DIA. (IN)	WALL THK (IN)	LENGTH	C SQ (IN)	BOLT CIRCLE (IN)	C THK (IN)	N DIA (IN)	J LENGTH (IN)	I HOOK (IN)	SPAN LENGTH	END DIA (IN)	END DIA (IN)	WALL THK (IN)	LENGTH (FT)	A SQ (IN)	U THK (IN)	L BOLT SIZE	BOLT CTRS (IN)	GUSSET THK (IN)
		STYLE	SPAN (FT)	STYLE	SPAN (FT)																			
20	NL, LR, MR, HR	A OR B	6-15	A OR B	6-15	12	3/16	17	16	2	1 1/2	54	6	20'-0"	8.0	5.20	3/16	20	17 1/4	2	1 1/4-7NC	14	1/4	
22	NL, LR, MR, HR	A OR B	6-15	A OR B	6-15	12.5	3/16	17 1/2	16 1/2	2	1 1/2	54	6	22'-0"	9.0	5.92	3/16	22	17 3/4	2	1 1/4-7NC	14 1/2	1/4	
24	NL, LR, MR, HR	A OR B	6-15	A OR B	6-15	12.5	3/16	17 1/2	16 1/2	2	1 1/2	54	6	24'-0"	9.0	5.64	3/16	24	17 3/4	2	1 1/4-7NC	14 1/2	1/4	
26	NL, LR, MR, HR	A OR B	6-15	A OR B	6-15	12.5	3/16	17 1/2	16 1/2	2	1 1/2	54	6	26'-0"	9.0	5.36	3/16	26	17 3/4	2	1 1/4-7NC	14 1/2	1/4	
28	NL, LR, MR, HR	A OR B	6-15	A OR B	6-15	12.5	3/16	17 1/2	16 1/2	2	1 1/2	54	6	28'-0"	9.0	5.08	3/16	28	17 3/4	2	1 1/4-7NC	14 1/2	1/4	
30	NL, LR, MR, HR	A OR B	6-15	A OR B	6-15	13	1/4	18 1/2	17 1/2	2	1 3/4	84	6	30'-0"	9.5	5.30	3/16	30	18 1/4	2	1 1/4-7NC	15	1/4	
32	NL, LR, MR, HR	A OR B	6-15	A OR B	6-15	13	1/4	18 1/2	17 1/2	2	1 3/4	84	6	32'-0"	10.5	6.02	3/16	32	18 1/4	2	1 1/4-7NC	15	1/4	
34	NL, LR, MR, HR	A OR B	6-15	A OR B	6-15	13	1/4	18 1/2	17 1/2	2	1 3/4	84	6	34'-0"	10.5	5.74	3/16	34	18 1/4	2	1 1/4-7NC	15	1/4	
36	NL, LR, MR, HR	A OR B	6-15	A OR B	6-15	13	1/4	18 1/2	17 1/2	2	1 3/4	84	6	36'-0"	11.0	5.96	3/16	36	18 1/4	2	1 1/4-7NC	15	5/16	
38	NL, LR, MR, HR	A OR B	6-15	A OR B	6-15	16	1/4	22	21	2 1/4	1 3/4	84	6	38'-0"	14.5	9.18	3/16	38	21 1/4	2	1 1/4-7NC	18	5/16	
40	NL, LR, MR, HR	A OR B	6-15	A OR B	6-15	16	1/4	22	21	2 1/4	1 3/4	84	6	40'-0"	13.0	7.40	1/4	40	21 1/4	2	1 1/4-7NC	18	5/16	
42	NL, LR, MR, HR	A OR B	6-15	A OR B	6-15	16	1/4	22	21	2 1/4	1 3/4	84	6	42'-0"	14.0	8.12	1/4	42	21 1/4	2	1 1/4-7NC	18	5/16	
44	NL, LR, MR, HR	A OR B	6-15	A OR B	6-15	16	1/4	22	21	2 1/4	1 3/4	84	6	44'-0"	14.5	8.34	1/4	44	21 1/4	2	1 1/4-7NC	18	5/16	
46	NL, LR, MR, HR	A OR B	6-15	A OR B	6-15	16	1/4	22	21	2 1/4	1 3/4	84	6	46'-0"	14.5	8.06	1/4	46	21 1/4	2	1 1/4-7NC	18	5/16	
48	NL, LR, MR, HR	A OR B	6-15	A OR B	6-15	16	1/4	22	21	2 1/4	1 3/4	84	6	48'-0"	14.5	7.78	5/16	48	21 1/4	2	1 1/4-7NC	18	5/16	
50	NL, LR, MR, HR	A OR B	6-15	A OR B	6-15	16	1/4	22	21	2 1/4	1 3/4	84	6	50'-0"	14.5	7.50	5/16	50	21 1/4	2	1 1/4-7NC	18	5/16	
52	NL, LR, MR, HR	A OR B	6-15	A OR B	6-15	17	1/4	23	22	2 1/4	2	84	6	52'-0"	15.0	10.8	5/16	30	23 1/4	2 1/2	1 1/2-6NC	19 1/2	5/16	
54	NL, LR, MR, HR	A OR B	6-15	A OR B	6-15	17	1/4	23	22	2 1/4	2	84	6	54'-0"	15.0	10.8	3/8	30	23 1/4	2 1/2	1 1/2-6NC	19 1/2	5/16	
55	NL, LR, MR, HR	A OR B	6-15	A OR B	6-15	17	1/4	23	22	2 1/4	2	84	6	55'-0"	15.0	10.8	3/8	30	23 1/4	2 1/2	1 1/2-6NC	19 1/2	5/16	
56	NL, LR, MR, HR	A OR B	6-15	A OR B	6-15	17	1/4	23	22	2 1/4	2	84	6	56'-0"	15.0	10.8	3/8	30	23 1/4	2 1/2	1 1/2-6NC	19 1/2	5/16	
58	NL, LR, MR, HR	A OR B	6-15	A OR B	6-15	17	1/4	23	22	2 1/4	2	84	6	58'-0"	15.5	11.3	3/8	30	23 1/4	2 1/2	1 1/2-6NC	19 1/2	5/16	
60	NL, LR, MR, HR	A OR B	6-15	A OR B	6-15	20	1/4	28	27	2 1/4	2	84	6	60'-0"	16.0	11.8	3/8	30	26 3/4	2 1/2	1 1/2-6NC	23	5/16	
62	NL, LR, MR, HR	A OR B	6-15	A OR B	6-15	20	1/4	28	27	2 1/4	2	84	6	62'-0"	16.5	12.3	3/8	30	26 3/4	2 1/2	1 1/2-6NC	23	5/16	
64	NL, LR, MR, HR	A OR B	6-15	A OR B	6-15	20	1/4	28	27	2 1/4	2	84	6	64'-0"	17.0	12.8	3/8	30	26 3/4	2 1/2	1 1/2-6NC	23	5/16	
66	NL, LR, MR, HR	A OR B	6-15	A OR B	6-15	20	1/4	28	27	2 1/4	2	84	6	66'-0"	17.5	13.3	3/8	30	26 3/4	2 1/2	1 1/2-6NC	23	5/16	
68	NL, LR, MR, HR	A OR B	6-15	A OR B	6-15	20	1/4	28	27	2 1/4	2	84	6	68'-0"	18.5	14.3	3/8	30	26 3/4	2 1/2	1 1/2-6NC	23	5/16	
70	NL, LR, MR, HR	A OR B	6-15	A OR B	6-15	20	1/4	28	27	2 1/4	2	84	6	70'-0"	18.5	14.3	3/8	30	26 3/4	2 1/2	1 1/2-6NC	23	5/16	

SEE TABLE 2

TABLE 2: ELEVATIONS		
POLE ELEV. TYPE	LUM. MTG HEIGHT	POLE SHAFT LENGTH
NO LUMINAIRE (NL)	----	19'-0"
NO LUM (NL) FOR 52'0 & GREATER ARMS	----	19'-6"
LOW RISE (LR)	30'-0"	27'-0"
MEDIUM RISE (MR)	35'-0"	32'-0"
HIGH RISE (HR)	40'-0"	37'-0"

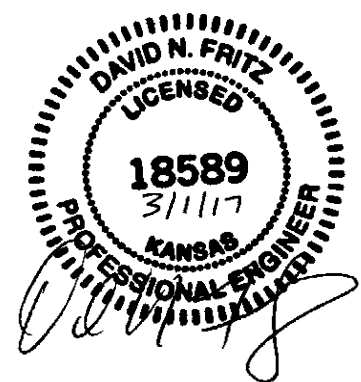

THIS DOCUMENT CONTAINS CONFIDENTIAL INFORMATION AND IS THE PROPERTY OF MILLERBERND MFG AND MAY NOT BE COPIED, REPRODUCED OR DISCLOSED IN ANY MANNER WITHOUT THE EXPRESS WRITTEN CONSENT FROM MILLERBERND MFG

PROJECT: _____

DWN: REBEKAH DATE: 07-29-14

CHK BY: DOUG F. DATE: 8/1/14

MATERIAL: _____

WEIGHT: _____ SCALE: NTS SHT-SIZE: B

DRWG NO.: 780B1885

SHEET: 3 OF 3 REV LEVEL: C

MILLERBERND 622 6TH ST. SO. WINSTED, MN 55395

DESCRIPTION: ROUND TRAFFIC SIGNAL STANDARD OVERLAND PARK, KS 2013 AASHTO