

Part Number	Size	"R"	"O"	"H"	"S" MIN	"B" MIN	"L"
5233746	1 1/4	7.250	1.000	3.625	2.000	1.500	3.81
5233748	2	9.500	1.250	4.750	3.125	2.000	5.00
5233750	3	13.000	1.750	6.500	3.250	2.500	6.81
5233751	3 1/2	15.000	2.000	7.563	3.375	3.250	7.88
5233776	4	16.000	2.063	8.000	3.625	3.250	8.38
5233753	5	27.000	3.188	12.000	3.750	4.250	12.56
5233754	6	30.000	4.000	15.000	6.625	5.000	15.69

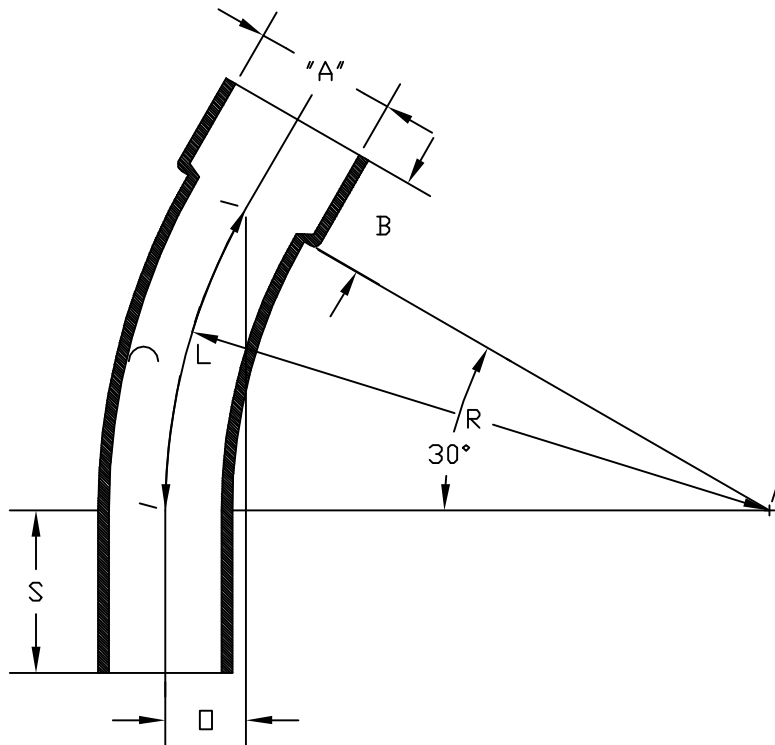

ETL LISTED
 CONFORMS TO UL651
 ETL CONTROL #3107144
 CONFORMS TO NEMA TC3
 SEE NEC ARTICLE 352 FOR USE
 MATERIAL IS RIGID PVC
 BEND TOLERANCE IS $\pm 2^\circ$
 "B" TOLERANCE IS $-\frac{1}{8}$ ", $+\frac{1}{2}$ "



CANTEX
 INC.
 Fort Worth, Texas

30° Elbows Bell End
 Schedule 40 Standard Radius Elbows

Drawn By: CD Branch | Date:10/15/07 | Ref.