

# W|ECO® FOLDING ARROW-BOARD TRAILERS

MODEL WTSP  
PRODUCT SPECIFICATIONS | MARCH 2017

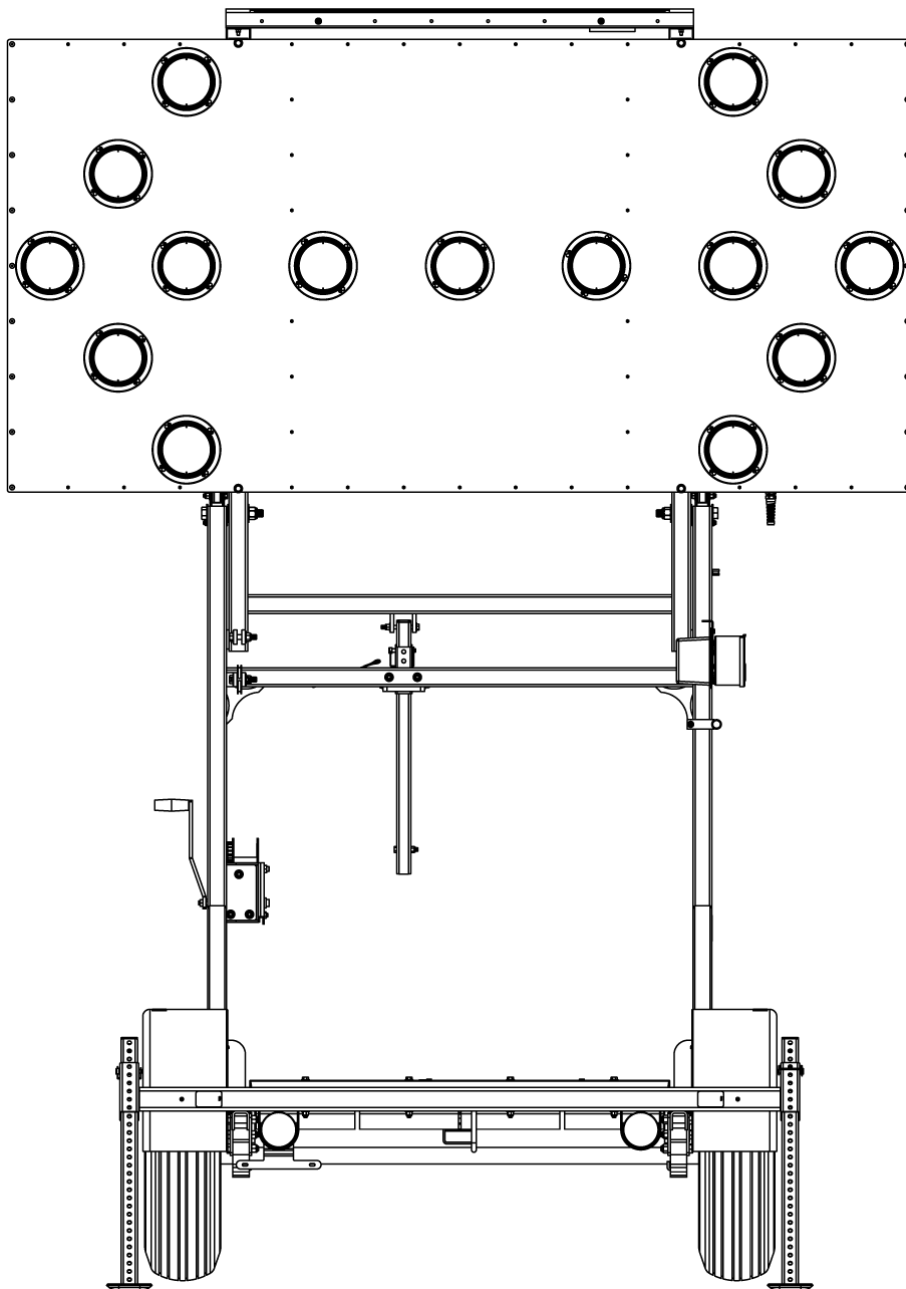

## 1. DESCRIPTION

- 1.1. Description Arrow boards direct traffic by flashing a brightly lit arrow pattern on a large, highly visible display panel. Wanco® arrow boards are portable and self-powered, requiring no permanent installation or wiring. Arrows and other patterns are selected by the user.
- Wanco Folding Arrow Board Trailers features a display panel that pivots up to the vertical position when deployed, and down to the horizontal position for transport. The display is held in place with a single support for ease of use.
- Wanco trailer-mounted arrow boards feature W|ECO® technology, a highly efficient power system. With Wanco's exclusive LED lamps and small, eco-friendly batteries, W|ECO arrow boards are extremely energy-efficient without sacrificing performance. Power is provided by batteries, which are charged by an automated solar charging system. With sufficient sunlight, W|ECO arrow boards can run indefinitely without intervention.
- 1.2. Models
- 1.2.1. WTSP-LSA Arrow-board trailer with 15-light display panel
- 1.2.2. WTSP-LSAC Arrow-board trailer with 25-light display panel

## 2. FEATURES

- 2.1. Operation
- High-output amber LEDs
  - Selection of arrow and other display patterns
  - Easy to operate and maintain
  - Heavy-duty hand-winch with safety brake allows one person to raise board
  - Single locking device holds arrow board in place while operating and during transport
  - Controller located safely away from traffic
  - Weather-resistant control box cover has lockable slam-latch
  - Control box outputs have short-circuit protection, helping prevent blown transistors
  - Arrow display has automatic dimming
  - Stabilizer legs raise tires off the ground to provide stability in high wind
  - Meets MUTCD
- 2.2. Power system
- Energy-efficient operation results in long run times
  - Solar panels charge batteries automatically without intervention
  - System disconnects solar charging system from batteries when they are fully charged, preventing over-charging and damage to batteries
  - Unique system allows battery charging with solar panels or commercial power
  - Power system includes reverse polarity protection and low-voltage disconnect circuit
  - Controller has resettable fuses
  - Solar charging system features solid state voltage regulator with charge indicator

- 2.3. Maintenance
- Maintenance-free batteries
  - Durable powder-coat finish resists the elements
  - In travel position, unique design supports board without rear braces, reducing possibility of damage during transport or storage
  - Lamps and visors are easily replaced
  - Standard trailer tires
  - Heavy-duty bolt-on steel fenders can be replaced if damaged
- 2.4. Environmental
- Consumes 80% less power than traditional solar arrow boards
  - Smaller batteries have 80% less lead content
  - Sealed batteries will not leak or spill
  - Decreased charging time saves energy and downtime
  - Manufacturing process emits near-zero VOCs
  - Nearly every component can be recycled
- 2.5. Application
- Common applications include:
- Roadwork zones
  - Lane, road and bridge closures
  - Public events

### 3. DISPLAY

#### 3.1. Display panel

- 3.1.1. Description Weather-resistant cabinet provides a rigid platform for LED lamps
- 3.1.2. Size 48" x 96" x 3" (122 x 244 x 8cm)
- 3.1.3. Height When deployed, 84" (213cm) from ground to bottom of display panel
- 3.1.4. Construction Outer frame constructed of aluminum channel, 3" x 1" x 1/8" thick. Two interior channels add strength and prevent distortion of front and rear panels. All channel joints are welded.
- Front and rear panels constructed of aluminum sheet, 5052-H32, 0.062" (1.575mm) thick. Panels are riveted and screwed to frame and interior channels.
- 3.1.5. Finish Oven-baked, flat-black (10% gloss), powder-coat finish ensures durability and corrosion protection. Panel assembly is high-pressure phosphate-washed prior to finish coat.
- 3.1.6. Wiring Weatherproof wiring between solar panel, control box, and display panel is P-clamped to trailer frame
- 3.1.7. Storage When lowered for storage and transport, the display panel is held in place without rear braces. As a result, the panel never strikes another surface during transport, eliminating damage that might otherwise occur (such as abrasion, deformation, and warping).

3.2. Front lights

3.2.1.	Description	Display lights are laid out across the front face of the display panel. The layout allows for a variety of arrows and other patterns to appear depending on which lights are lit. The desired pattern is selected by the operator, using the arrow board controls.	
3.2.2.	Type	PAR 46 LED lamp, 5¾" (14.5cm) dia.	
3.2.3.	Wattage	<1.0W per lamp	
3.2.4.	Voltage	8.0Vdc	
3.2.5.	Light output	1425 lux per lamp	
3.2.6.	Reverse-polarity protection	Protects lamps if control box wiring is connected backwards (which sometimes happens after servicing)	
3.2.7.	LEDs	Technology	AllnGaP II (aluminum indium gallium phosphide) technology, T-1¾ size
		Color range	Amber, 590 to 593 nm
		Forward voltage	2.0 to 2.1Vdc @ 20mA
		Temperature limits	Operating temperature, -22 to 185°F (-30 to 85°C)
3.2.8.	Lens	Function	Each lamp has an integrated hex lens that enhances the brightness and angularity of each LED while reducing power consumption
		Material	Acrylic
		Beam angle	Horizontal: 16.8 degrees, ±8.4 degrees Vertical: 9.5 degrees, ± 4.75 degrees  Angle determined by 10% of peak candle power (certified by independent testing laboratory)
3.2.9.	Visor	Function	Each lamp is shrouded by a visor that enhances visibility by shading the lamp and preventing glare
		Material	High-impact ABS plastic
		Mounting	Four keyed slots enable visor to be removed from the display panel without removing screws
3.2.10.	Visibility	At least 1 mile (1.6km)	
3.2.11.	Angularity	26.8 degrees @ 105 ft. (32m) 54.0 degrees @ 49 ft. (15m)  Total viewing area, per 2008 NTPEP results	

- 3.2.12. Auto-dimming      A photocell detects ambient light; the controller adjusts the brightness of the LEDs accordingly, dimming display brightness in darkness, increasing to full brightness in daylight  
  
    Photocell is located inside control box, facing downward
- 3.2.13. Replacement      Lamps can be replaced in less than two minutes. The only tool needed is a Philips screwdriver.
- 3.3.      Rear lights
  - 3.3.1.      Description      Two indicator lights on the back of the display panel suggest the current arrow board function to an operator located behind the arrow board by flashing a corresponding pattern
  - 3.3.2.      Type      Sealed 2-diode LED light, surface-mount, 2½" x ¾" (6.6 x 1.9cm) lens  
  
    See "Options and Optional Equipment" for rear light options
  - 3.3.3.      Wattage      0.9W
  - 3.3.4.      Voltage      8.0Vdc
- 3.4.      Standards      Meets requirements for minimum size, legibility, and number of elements per MUTCD, December 2009 ed., §6F.61, ¶105, Temporary Traffic Control Zone Devices: Arrow Boards  
  
    Meets specs for MUTCD Type C

#### **4.      CONTROLLER**

- 4.1.      Function      Allows operator to choose an arrow or other display pattern. Keeps the batteries fully charged while protecting them from deep discharge and overcharging. Maintains display flash-rate and controls automatic dimming.
- 4.2.      Control box
  - 4.2.1.      Location      Right (curb-side) upright of trailer frame
  - 4.2.2.      Enclosure      Aluminum sheet construction, brushed aluminum finish  
  
    Hinged weatherproof cover with slam-latch  
  
    Hole in cover accepts customer-supplied padlock
  - 4.2.3.      Cable protection      Molded plastic cover attached to back of control box, protects external wiring connections and can be removed for access to connectors; all wiring has quick-connect plugs
  - 4.2.4.      Serviceability      Entire control box is removable for easy exchange and factory servicing
- 4.3.      Control panel
  - 4.3.1.      Display switch      Toggle switch for turning arrow board display on and off

- 4.3.2. Display pattern selection Rotary switch; operator simply points the switch at the desired display pattern, which is silkscreened onto the front of the control panel
- 4.3.3. LED indicators Indicates the following status conditions:  
Low voltage (battery charging required)  
Low battery voltage detected, power shutdown occurred  
Solar charging system is charging batteries  
Batteries are fully charged
- 4.4. Display patterns
- 4.4.1. All models All arrow boards can display any of the following 7 patterns (for samples, see Exhibit A):
- |                                      |  |
|--------------------------------------|--|
| Flashing arrow, left or right        | 10 lights total<br>5 lights form arrowhead<br>5 lights form stem   |
| Flashing double arrow                | 13 lights total<br>5 lights form each arrowhead<br>3 lights form stem  |
| Flashing four-corner warning         | 4 lights total<br>1 light at each corner   |
| Flashing caution-bar warning         | 7 lights form horizontal bar across center of display panel  |
| Sequencing stem arrow, left or right | 10 lights total<br>5 lights form arrowhead<br>5 lights form full stem<br><br>1st pulse: 2 far stem lights<br>2nd pulse: 5 far stem lights<br>3rd pulse: full arrow shape<br>4th pulse: blank display |
- 4.4.2. 25-light models In addition to the 7 patterns described above, 25-light arrow boards can also display any of the following 5 patterns (for samples, see Exhibit A):
- |   |  |
|---|--|
| Sequencing walking arrow, left or right | 10 lights total<br>5 lights form arrowhead<br>5 lights form full stem<br><br>1st pulse: 2 far stem lights with arrowhead<br>2nd pulse: 3 far stem lights with arrowhead<br>3rd pulse: full arrow shape<br>4th pulse: blank display |
|---|--|

Sequencing chevron arrows, left or right	15 lights total 5 lights form each arrowhead  1st pulse: 1 far arrowhead 2nd pulse: 2 far arrowheads 3rd pulse: 3 arrowheads 4th pulse: blank display
Alternating diamonds	16 lights total 8 lights form each diamond  1st pulse: 1 diamond shape on left 2nd pulse: 1 diamond shape on right

#### 4.5. Electronics

- |                                    |  |
|------------------------------------|--|
| 4.5.1. Location                    | Inside control box   |
| 4.5.2. Temperature limits          | Operating temperature: -40 to 176°F (-40 to 80°C)  |
| 4.5.3. Flash rate                  | 30 to 40 per minute, all display patterns  |
| 4.5.4. Positive drive circuit      | Positive power applied to lamps only when lit<br>Negative is chassis grounded  |
| 4.5.5. Fuse protection             | Dual PTC resettable fuses  |
| 4.5.6. Reverse-polarity protection | Protects the controller if battery cables are connected backwards (which sometimes happens after servicing)                                |
| 4.5.7. Low-voltage disconnect      | Low-voltage-disconnect circuit engages when battery voltage drops to 11.2Vdc, shutting down power to protect batteries from full discharge |

### 5. TRAILER

- |                |   |
|----------------|---|
| 5.1. Frame     | All welded structural steel   |
| 5.2. Deck      | Structural deck adds 350 lb. (159kg) to overall weight, creating a low center of gravity and improving stability when deployed or towed |
| 5.3. Uprights  | Two uprights supported display panel, reinforced by 23" structural steel gussets, all welded steel construction                         |
| 5.4. Fenders   | Round, full wheel coverage, bolted to trailer frame<br>Material: 16ga steel   |
| 5.5. Tie-downs | One on each front corner of frame, one centered on rear frame   |

- 5.6. Finish
  - 5.6.1. Prewash Assemblies are run through a five-stage, high-pressure phosphate-wash prior to finish coat
  - 5.6.2. Coating Frame is coated with oven-baked, safety-orange powder-coat finish to ensure durability and corrosion protection  
See "Options and Optional Equipment" for color options
  - 5.6.3. Salt spray resistance 1000 hours (ASTM Method B117) with <1/8" (<3.18mm) creep from scribe
  - 5.6.4. QUV exposure 500 hours QUV-B (ASTM Method D4587-05) >75% gloss retention
- 5.7. Axle assembly Tubular, 2000 lb. (907.2kg) capacity, 5 on 4.5" B.C. idler hub
- 5.8. Springs Double-eye leaf springs, 1200 lb. (544.3kg) capacity for each spring
- 5.9. Tires ST205/75D15 steel-belted trailer tires, load rating B
- 5.10. Drawbar
  - 5.10.1. Construction Telescopes inside receiver sleeve welded under trailer frame. Removable for shipping and for added theft protection if needed. Secures with two 1/2-inch diameter bolts.
  - 5.10.2. Material 3" (7.62cm) square steel tubing, 3/16" (0.476cm) wall
  - 5.10.3. Jack Top-wind swivel, 2000-lb. (907kg) capacity, steel footpad, 10" (25cm) total travel
  - 5.10.4. Tow hitch Standard 2-inch ball coupler tow-hitch, SAE Class 2, 3500-lb. (1588kg) capacity. Bolts to drawbar, removable and replaceable.  
See "Options and Optional Equipment" for tow-hitch options.
  - 5.10.5. Tow chains Two high-test proof coil chain assemblies, with "latching" S-hooks for towing. Chains attached to drawbar with quick connectors.
    - Material diameter 0.406" (10.3mm)
    - Working load limit 5400 lbs. (2450kg)
    - Breaking force 16,200 lbs. (72kN)
- 5.11. Stabilizer legs
  - 5.11.1. Description Four stabilizers, mounted on corners of trailer frame, extend downward from front and rear of trailer at 30-degree angle, increasing length of footprint when deployed
  - 5.11.2. Adjustment Stabilizers slide up and down in sleeves, adjustable in 1" (2.54cm) increments, held in place by 3/8" (0.95cm) wire lock pin. A lanyard ties each pin to the trailer frame.
  - 5.11.3. Material
    - Leg Perforated 1¼" sq. steel tube, 12ga wall, zinc plated
    - Footpad 4" x 6" (10 x 15cm) steel, zinc plated, all edges turned up



- 5.12. Wind resistance      Approx. 57mph (91km/h), calculated maximum sustained wind load before overturning, trailer in deployed position supported by four stabilizer legs and one drawbar jack with tires off the ground
- 5.13. Wiring
  - 5.13.1. Description      Wiring to connect tow vehicle and trailer for trailer taillights is installed inside drawbar, with pigtails and connectors at both ends; no crimping required
  - 5.13.2. Trailer plug      A sealed, molded, 4-square connector plugs into harness under trailer
  - 5.13.3. Tow-vehicle plug      Two-piece assembly with 4-flat molded connector on harness plugs into tow vehicle  
Meets SAE J1239  
  
See “Options and Optional Equipment” for tow-vehicle plug options
  - 5.13.4. Protection      All trailer wiring encased in UV protective loom, and attached with P-clamp riveted to trailer frame; no exposed wires
- 5.14. Taillights
  - 5.14.1. Type      Two round, sealed, combination stop, turn and taillights
  - 5.14.2. Location      Bottom of rear trailer frame
  - 5.14.3. Mounting      Light assembly is bolted to bracket and protected by steel shroud; bracket and shroud are welded to trailer frame
- 5.15. License plate      License plate light holder is mounted below left taillight and lighted by the taillight
- 5.16. Reflectors      Two amber reflectors, one on the side of each upright  
Two red reflectors on rear trailer frame  
  
See “Options and Optional Equipment” for reflective tape
- 5.17. Winch assembly
  - 5.17.1. Function      Hand-operated winch raises and lowers display panel
  - 5.17.2. Capacity      1500 lbs. (680kg)
  - 5.17.3. Brake      Safety friction-brake prevents display panel from falling if operator loses grip on winch handle
  - 5.17.4. Cable      1/4" (6.35mm) diameter galvanized aircraft cable
- 5.18. Slide-bar assembly
  - 5.18.1. Function      Locks display panel in place, ensuring panel cannot fall even if winch or cable were to fail. Slides up and down inside sleeve when winch is operated.  
  
Located off-center on upper crossbar between uprights. Sleeve is mounted to crossbar. Slide-bar is mounted to back of display panel.

- 5.18.2. Locking pin One 3/8" (0.95cm) wire lock pin holds slide bar and display panel in deployed or travel position. A lanyard ties the pin to the trailer frame.
- 5.18.3. Material Perforated 1¼" sq. steel tube, 12ga wall, zinc plated
- 5.18.4. Sight tube A sight tube for aiming the arrow board in desired direction is mounted to the left upright

## 6. POWER SYSTEM

- 6.1. Description Electronics powered by batteries, which are charged automatically with integrated solar charging system
- 6.2. Battery box
  - 6.2.1. Function Holds batteries and optional remote charger
  - 6.2.2. Construction Riveted all-steel construction, cover is bolted in place  
Removable panel on side of battery box provides access to optional remote charger  
All parts powder-coated before assembly
  - 6.2.3. Mounting Bolted to trailer frame behind deck
- 6.3. Batteries
  - 6.3.1. Type Leak- and spill-proof valve-regulated lead acid (VRLA)  
See "Options and Optional Equipment" for battery options
  - 6.3.2. Features 100% maintenance-free  
Sealed and spill-proof  
Faster recharge and greater freeze resistance than conventional batteries  
Smaller and lighter-weight than conventional batteries  
Contains 80% less lead when compared to conventional batteries
  - 6.3.3. Quantity Two
  - 6.3.4. Voltage 12Vdc each
  - 6.3.5. Weight 12.5 lbs. (6kg) each
  - 6.3.6. Capacity 48 Ah total @ 12Vdc
- 6.4. Solar
  - 6.4.1. Panels One high-efficiency multi-crystal photovoltaic solar module
  - 6.4.2. Location Above display panel, no shadowing effect on any trailer component. Articulated supports ensure solar array remains flat for continuous charging regardless of display panel position.

- 6.4.3. Power 50W  
 See "Options and Optional Equipment" for solar options
- 6.4.4. Current 2.89A max. system current  
 3.22A open short-circuit current
- 6.4.5. Voltage 17.3Vdc max.  
 21.6Vdc open short-circuit voltage
- 6.4.6. Regulation Solar panels regulated by arrow board controller
- 6.4.7. Security Solar panel bolted to mounting frame with security screws and special security nut

**7. DIMENSIONS & WEIGHT**

- 7.1. Dimensions *inches (cm)*

**Travel position**

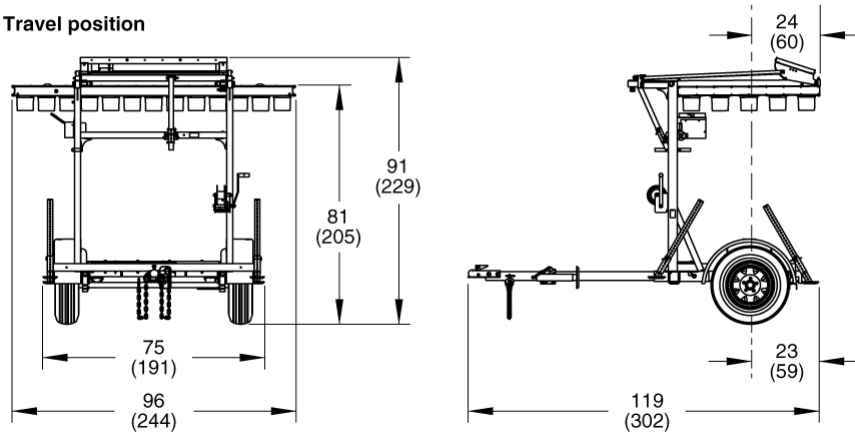

**Deployed**

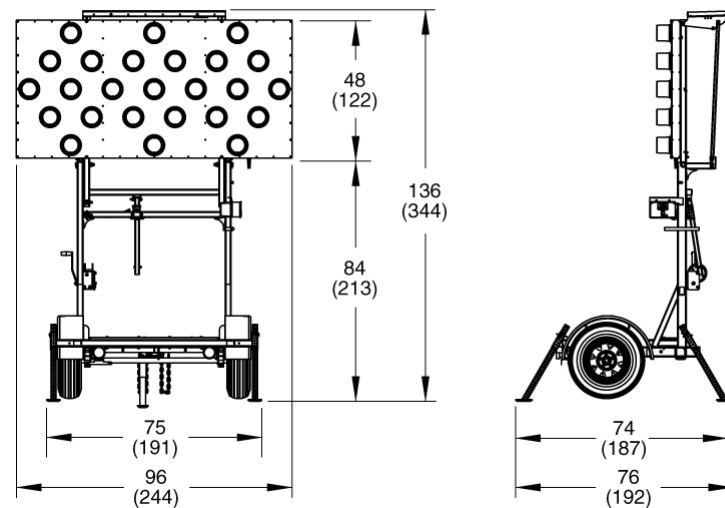





- 7.2. Weight Approx. 1250 lbs. (567kg)







	Large battery box	Replaces standard battery box Centered over trailer axle, bolted to trailer frame Riveted all-steel construction All parts powder-coated before assembly Divider panel inside box separates batteries from charger Louvers provide ventilation Latches keep cover closed and can accept user-supplied padlocks
8.4.3.	Remote charger	Function Plugs into a standard commercial power source to recharge batteries if battery voltage drops due to lack of sun for automated solar charging system
	Type	12-volt battery charger
	Location	Inside battery box
	Smart charger	Three-stage smart-charging circuit keeps batteries fully charged, and will not overcharge batteries, which helps to ensure the longest possible battery life
	Output capacity	2A
	Output voltage	14.4Vdc nominal 13.0Vdc nominal float voltage
	Input voltage	90 to 132Vac, standard two-prong plug
	Frequency	50 to 60 Hz
8.4.4.	Solar	For geographic locations with smaller solar charging potential, and for applications that require a year-round charging system, additional solar power is available Options include 85W and 100W solar arrays; contact factory for details
8.5.	<b>Reflective tape</b>	Reflective red-and-white conspicuity tape across rear trailer frame for increased visibility
8.6.	<b>Finish color</b>	Specify power-coat color and, if applicable, color scheme
8.7.	<b>Manual dimming</b>	Substitute control box with manual dimming control for standard control box
8.8.	<b>Rear lights</b>	Replace standard rear lamps with PAR 36 LED lamps, 4.5" (11.5cm) dia.

**EXHIBIT A: DISPLAY PATTERNS**

**Flashing patterns**

Pulse 1	Pulse 2	
		Flashing arrow, left or right
		Flashing double arrow
		Flashing four-corner warning
		Flashing caution-bar warning

**Sequential patterns**

Pulse 1	Pulse 2	Pulse 3	Pulse 4	
				Sequencing arrow, left or right
				Sequencing stem arrow, left or right*
				Sequencing chevron arrows, left or right*
				Alternating diamonds*

*\*Available only on 25-light arrow board models*