

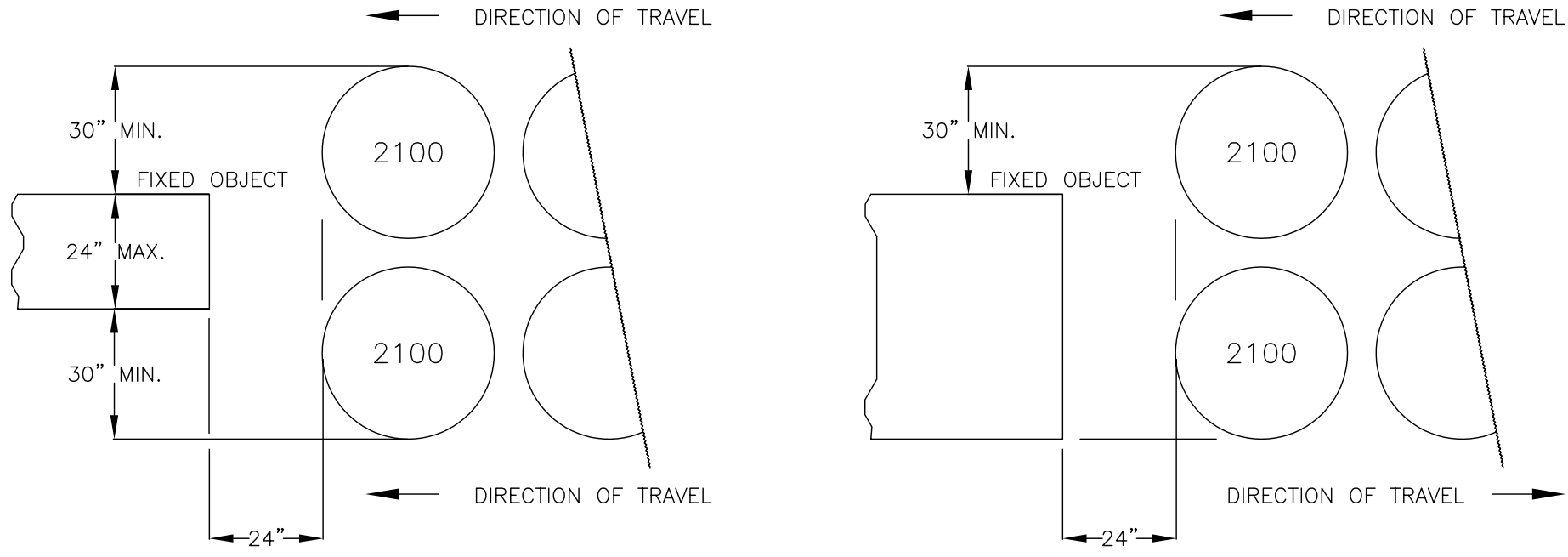

REVISIONS				
ZONE	REV	DESCRIPTION	DATE	APPROVED
	A	INITIAL RELEASE	7/9/02	DG
	B	ADDED FLAGNOTE 6	3/14/03	

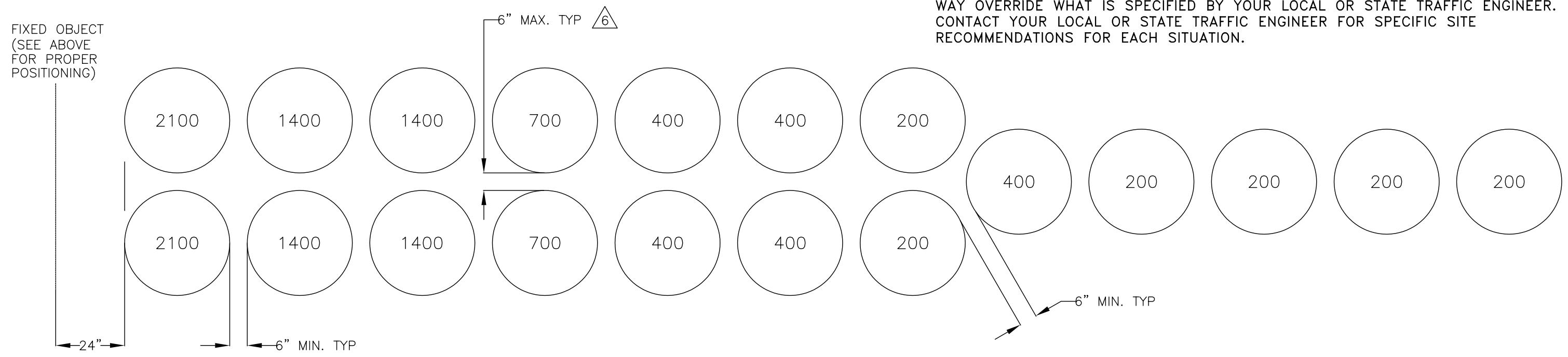

THIS DRAWING IS AN EXAMPLE OF A TYPICAL ARRAY PLAN AND SHOULD IN NO WAY OVERRIDE WHAT IS SPECIFIED BY YOUR LOCAL OR STATE TRAFFIC ENGINEER. CONTACT YOUR LOCAL OR STATE TRAFFIC ENGINEER FOR SPECIFIC SITE RECOMMENDATIONS FOR EACH SITUATION.



- △ FOR FIXED OBJECT WIDTHS GREATER THAN 18" INCREASE SPACING OF DOUBLE WIDE BARRELS UP TO 12" APART.
- PLACE THE TYPE P MARKER PANEL SO THAT THE BOTTOM OF THE PANEL IS AT THE BOTTOM OF THE MODULE.
 - MASS OF SAND AND OUTLINE OF EACH MODULE SHALL BE PAINTED ON THE SURFACE OF EACH MODULE LOCATION.
 - BIDIRECTIONAL CRASH CUSHION ARRAYS MAY BE ANGLED TOWARD APPROACHING TRAFFIC. AMOUNT OF ANGLE NOT TO EXCEED 10°.
 - EACH MODULE IS TO CONTAIN AMOUNT OF SAND INDICATED. ALL SAND MASSES ARE NOMINAL.
 - (XXX) INDICATES MODULE LOCATION AND MASS OF SAND IN POUNDS (LBS) FOR EACH MODULE. MODULE SPACING IS BASED ON THE GREATER DIAMETER OF THE MODULE.
- NOTES: UNLESS OTHERWISE SPECIFIED.

UNLESS OTHERWISE SPECIFIED: ALL DIMENSIONS ARE IN INCHES.		Traffix Devices Inc.  220 Calle Pintoresco San Clemente, CA 92672 (949) 361-5663 FAX (949) 361-9205 www.traffixdevices.com	
DRAWN BY: J. HARDMAN		DATE: 7/8/02	
CHECKED BY:		SIZE B	DWG NO. BA65
APPROVED BY: D. GERTZ		DATE: 7/8/02	REV B
SCALE NONE		SHEET 1 OF 1	