

- *AllnGaP LED technology*
- *Environmentally friendly*
- *Cost effective*
- *Reliable and easy to operate*
- *Hundreds of pre-programmed messages, MUTCD messages, and operator-created messages*
- *Replace characters without the need of tools*
- *5 LEDs per pixel, 15" letters*
- *Ergonomically designed control box*



Display

Pixel Matrix SR480	7 rows by 5 columns, 8 characters per line, 3 lines
Character size	15" fonts
LEDs	590 nm amber, 5 per pixel, 30°
Brightness	Manual/automatic 31 levels
Photo Sensor	Shielded from extraneous light
Enclosure	Aluminum, finished powder coated black
Sign dimensions	59" high by 96" wide
Characters	Removable without need for tools
Window	1/8" clear polycarbonate anti-glare is optional

Control

Type	Proprietary embedded fully NTCIP compliant
Dimming	Manual or automatic
LCD	4 lines, 40 characters per line, backlit
Remote Comm	Cellular capable
Messages	50 user programmable (4 pages each), 300 pre-programmed including MUTCD symbols and arrows
Message scheduling	36 events

Specifications

Trailer Construction

Width across fenders	78"
Drawbar	2 1/2" x 2 1/2" x .187" wall steel tube / removable
Fenders	formed steel replaceable
Frame	3" x 3" x 1/8" wall tubing
Length w/ drawbar	136"
Length w/o drawbar	106"
Height sign up	149"
Height sign down	104"
Hitch	2" ball class II 3500 lb capacity
Jacks	(4) swing, (1) swing type w/ caster
Tire size	ST205/75-D15 load C
Weight	1600 lbs
Lift Mechanism	2,500 lb with double disc brake. 1/4" diameter steel rope cable rated 4,400 lb. Electro-hydraulic optional

Batteries and Solar Collectors

Batteries	6v or 12v deep cycle with varying options
Battery Charger	15A to 30A fanned cooled, external plug, (45A optional)
Battery Enclosure	Lockable, ventilated, acid resistant
Solar Collector	Crystalline silicon, 85w

Options

- Combo hitch 2" ball & 3" pintle ring
- Speed detection
- Wheel locks
- Electro hydraulic lift
- Cellular phone for remote operation
- Color touch tablet
- Hidden shackle lock brackets to secure batteries

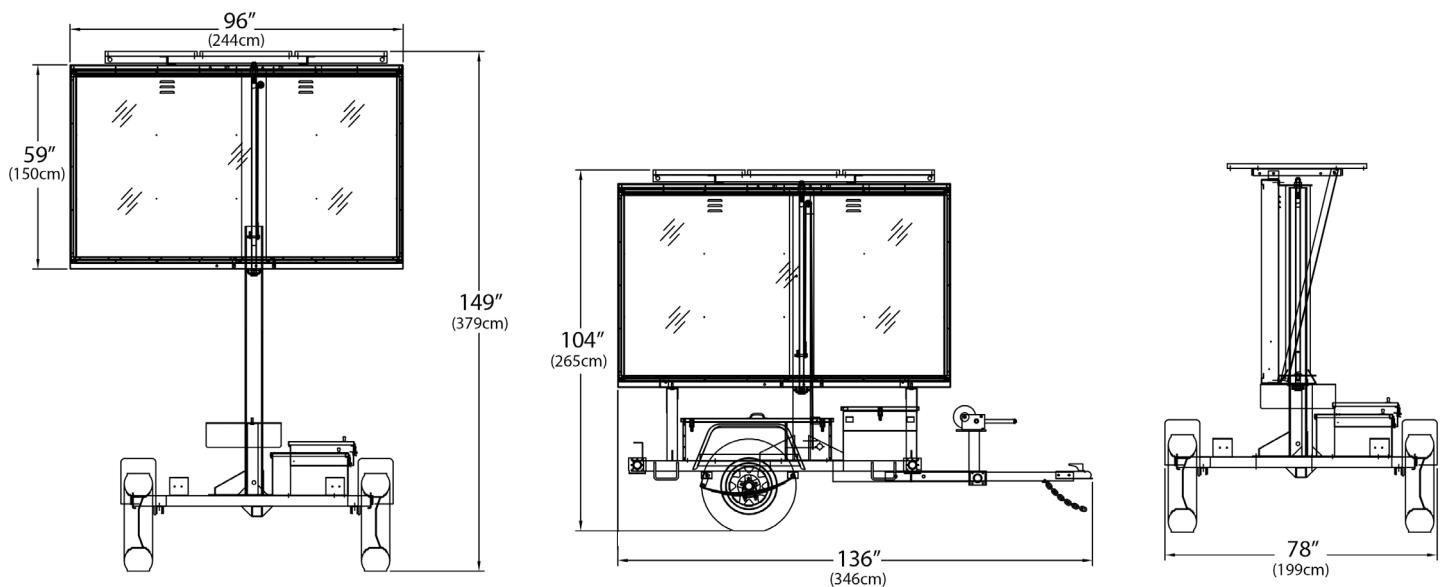

Specifications subject to change any time without notice. Copyright 2017 National Signal, Inc. All rights reserved. Printed in the United States.