

POLE RATING (PER AASHTO 2013):
 3-SEC GUST WIND SPEED: 90 MPH MAX
 EPA (LUMINAIRE): 1.3 SQ. FT. MAX
 WEIGHT (LUMINAIRE): 55 LBS MAX

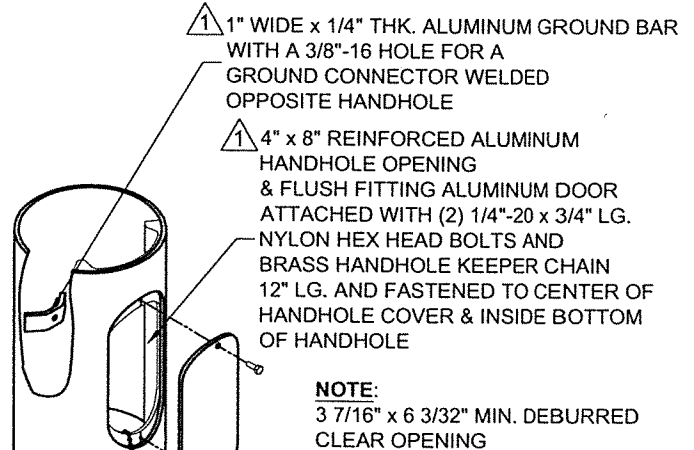

HANDHOLE DETAIL

TYPE OP401-6-6
 TYPE OP401-8-8

DO NOT SCALE



Valmont Industries, Inc. Structures Division
 20805 Eaton Ave Farmington, Minnesota 55024-7932
 Phone: (651) 463-8990 (800) 899-7577
 Fax: (651) 463-3349

****CONFIDENTIAL****

The information contained in this drawing is privileged and confidential, and may be protected from disclosure. Please be aware that any use or dissemination of this drawing may be subject to legal restriction or sanction.

TITLE: S TRANSFORMER BASE ALUMINUM POLE		QTY:
MODEL NO.: 370645807T4B		OWN BY: PVB
MATERIAL: ALUMINUM ALLOY		CHK'D BY:
FINISH: 100 GRIT SATIN POLISH		APPR BY: MP
PROJECT: CITY OF OVERLAND PARK, KS		DATE: 09-22-17
SOLD TO:		DWG NO: DSOP
SHIP TO:		PAGE:
P.O. NO:		REV
REP: POWER EQUIPMENT SALES		DATE
△		
△	04/06/18	UPDATED NOTES & J-HOOK SIZE
△		REVISION DESCRIPTION
		BY
		6 / 18