



PH: 405-340-3434
 FAX: 405-340-3435
 Edmond, OK 73013
 www.pelcoinc.com

This drawing is the property of Pelco and is not to be used in whole or in part without Pelco's written permission.

ASSEMBLY CUT SHEET

REF:
 Overland Park, KS

TITLE:
 Foundation Anchor Assy,
 6" x 60", 11" BC w/ 1"-8 Hardware, Steel

PART NO.:
 SP-3008-KS

Example Part No.
 SP-3008-KS-HKA-GLV
 Hardware Kit
 Galvanized

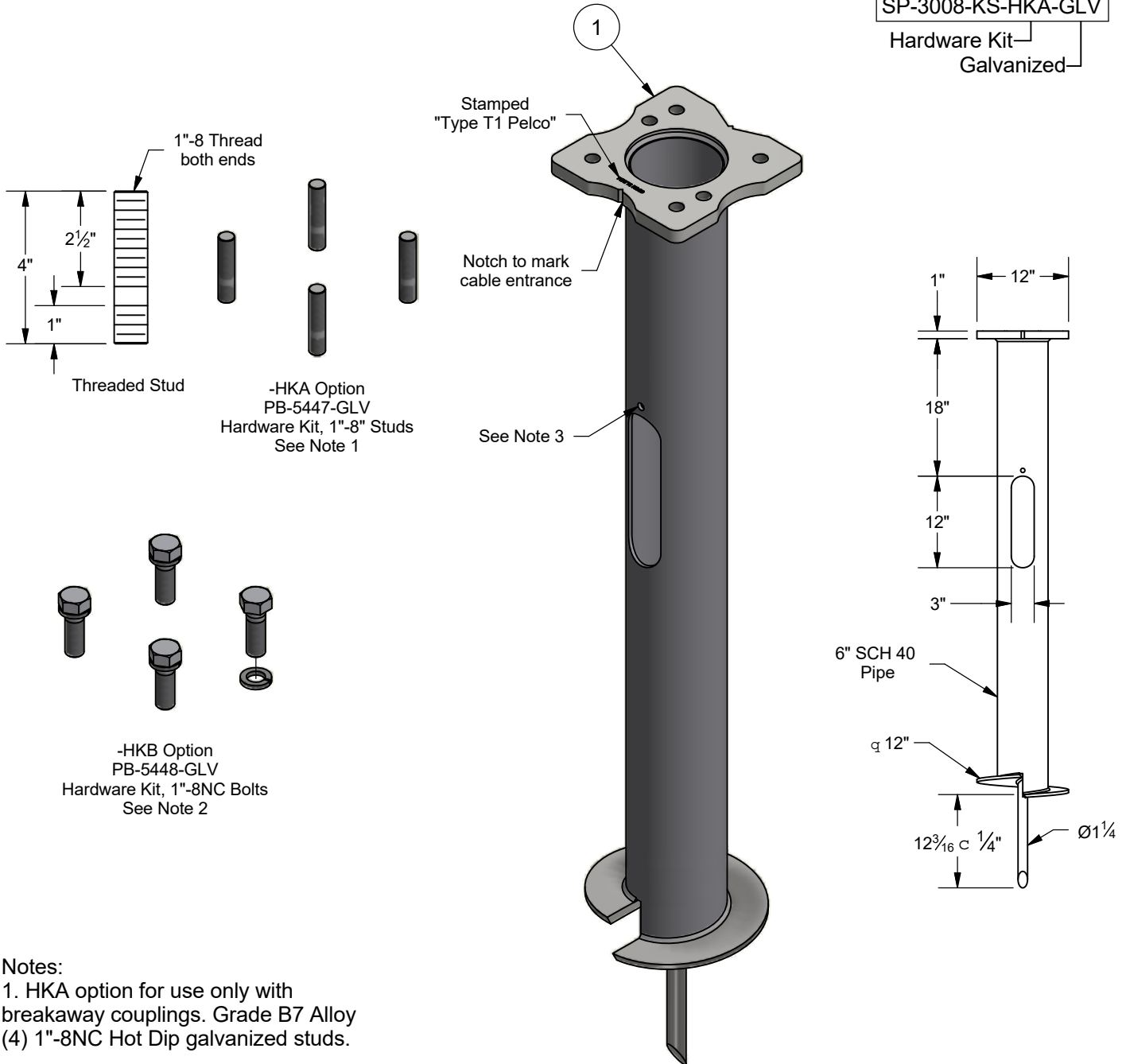

Notes:

- HKA option for use only with breakaway couplings. Grade B7 Alloy (4) 1"-8NC Hot Dip galvanized studs.
- HKB option for use only with frangible breakaway base. ASTM A325 or Gr 5 SAE J469 (4) 1"-8NC x 3" Hot Dip galv Hex Hd Bolts with (4) lockwashers.
- Place hardware in nylon weatherproof bag and attach to hole with drawstring.
- Type "T1" Anchor

Options	
Hardware Kits:	
HKA=Threaded Studs	
HKB=Hex Hd Bolts	
GLV=Galvanized	

Pelco Assy.dwg 8/20/18

ITEM	PART NUMBER	DESCRIPTION	QTY
1	SP-3008-KS-1-GLV	Weldment, Foundation Anchor, 6" x 60" Lg x 11" BC, Steel, Galv	1

Christina.Madden4/30/2008	R WOODS	5/1/2008	KAK	8/24/2018	RKV	9/11/2018	H	12/3/19 TRL	KAK	12/4/2019	SHEET 1 OF 1
DRAWN:	CHECKED:	DATE:	MFG ENG:	DATE:	QA:	DATE:	REV:	DATE:	REV CHKD:	DATE:	