

REF:
Overland Park, KS

TITLE:
Foundation Anchor Assy, 8" x 60", 14-1/2" BC
w/ Hardware, Steel, Galv

PART NO.:
SP-3012-KS

Example Part No.
SP-3012-KS-HKA-GLV
Hardware Kit Galvanized

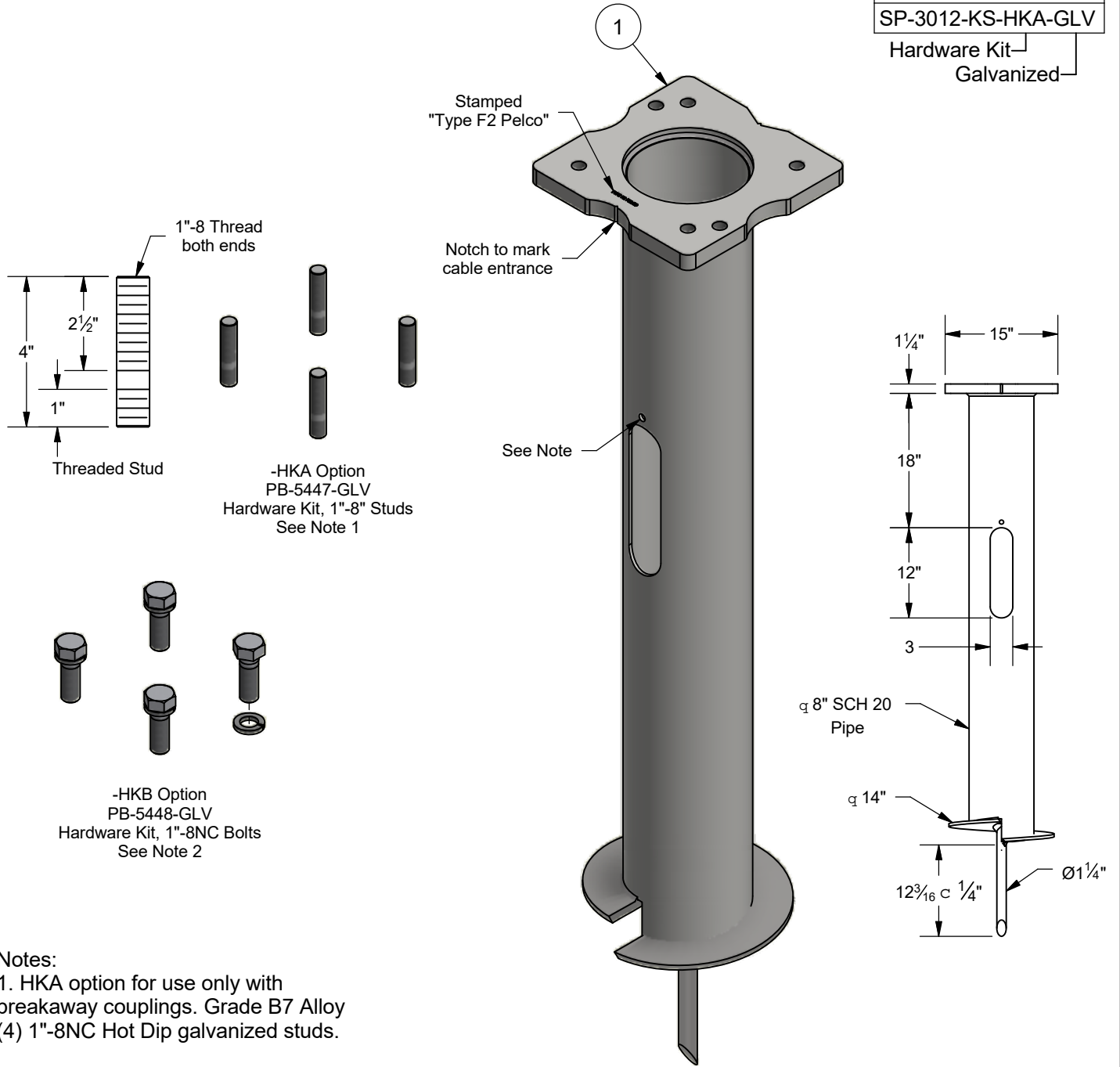

Notes:

- HKA option for use only with breakaway couplings. Grade B7 Alloy (4) 1"-8NC Hot Dip galvanized studs.
- HKB option for use only with frangible breakaway base. ASTM A325 or Gr 5 SAE J469 (4) 1"-8NC x 3" Hot Dip galv Hex Hd Bolts with (4) lockwashers.
- Place hardware in nylon weatherproof bag and attach to hole with drawstring.
- Type "F2" Anchor

Options	
Hardware Kits:	
HKA=	Threaded Studs
HKB=	Hex Hd Bolts
GLV=	Galvanized

Pelco Assy.dwg 8/20/18

ITEM	PART NUMBER	DESCRIPTION	QTY
1	SP-3012-KS-1-GLV	Weldment, Foundation Anchor, 8" Sch 20 x 60" Lg x 14-1/2" BC, Steel, Galv	1
D BOWENS DRAWN:	6/26/2008 DATE:	R WOODS CHECKED:	6/26/2008 DATE:
JDC MFG ENG:	3/31/2015 DATE:	RKV QA:	3/31/2015 DATE:
K REV:	12/3/19 TRL DATE:	KAK REV CHKD:	12/4/2019 DATE:
SHEET 1 OF 1			