



DERO
A PLAYCORE Company



Hoop Rack

Heavy Duty



For added security and peace of mind, the Heavy Duty Hoop Rack uses a larger, thicker pipe than our standard Hoop Rack. The Heavy Duty Hoop meets APBP guidelines for u-lock compatibility and two points of support for the bike.

Hoop Rack Heavy Duty



YOUR **LOGO** HERE

Customize the HoopRack Heavy Duty to brand your bike parking!



FINISH OPTIONS

Galvanized



Stainless



Powder Coat

- | | | | | |
|-------------------------|--------------------|-------------------------|-----------------------|--------------------------|
| White | Black | Light Gray
RAL 7042 | Deep Red
RAL 3003 | Yellow
RAL 1023 |
| CNH Bright Yellow | Orange
RAL 2004 | Beige
RAL 1001 | Iron Gray
RAL 7011 | Hunter Green
RAL 6005 |
| Light Green
RAL 6018 | Green
RAL 6016 | Sepia Brown
RAL 8014 | Blue
RAL 5005 | Sky Blue
RAL 5015 |
| Dark Purple | Flat Black | Wine Red
RAL 3005 | Bronze | Silver
RAL 9007 |

MOUNT OPTIONS

Surface

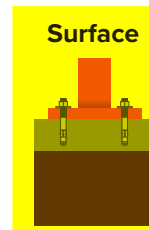

In-Ground

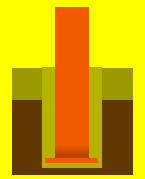

Tamper-resistant fasteners available upon request

Rail

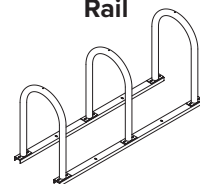

OPTIONAL LEAN BAR

for ADA cane-detection compliance

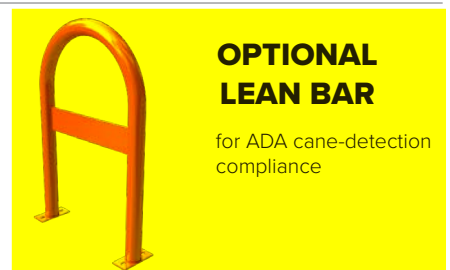

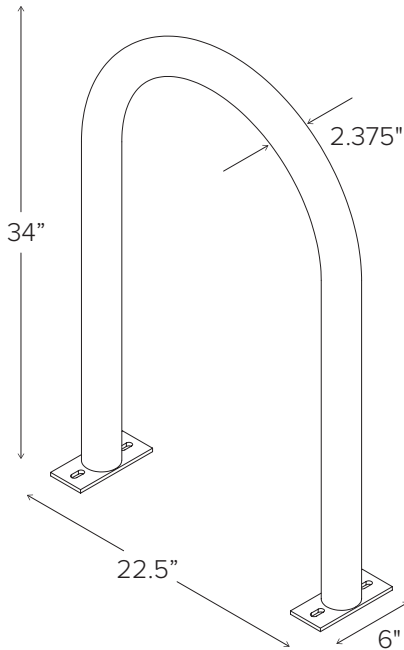

FOOTING DIAGRAMS

IN-GROUND MOUNT

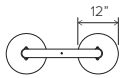

SURFACE MOUNT

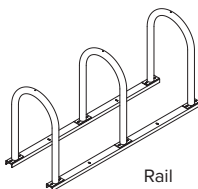
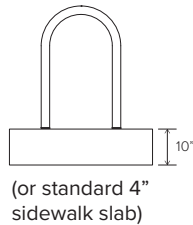
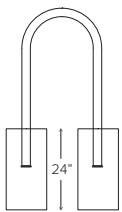
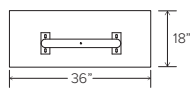

CAPACITY

2 Bikes

MATERIALS

2" schedule 40 pipe (2.375" OD)

FINISHES



Galvanized

An after fabrication hot dipped galvanized finish is our standard option.



Powder Coat

Our powder coat finish assures a high level of adhesion and durability by following these steps:

1. Chemically cleaned and treated for corrosion reduction
2. Epoxy primer electrostatically applied
3. Final thick TGIC polyester powder coat



Stainless

Stainless Steel: 304 grade stainless steel material in a satin finish, high polished shine, or powder coat over unpolished stainless.

- Satin Finish (#4) - Brushed (Our standard)
- Electropolished - High Polished Shine
- Powder Coat over Unpolished Stainless

MOUNT OPTIONS



Surface

Foot Mount has two 2.5" x 6" x .25" feet with two anchors per foot. Specify foot mount for this option. Tamper-resistant fasteners available upon request.



In-Ground

In-ground mount is embedded into concrete base. Specify in-ground mount for this option.



Rail

Rail Mounted Downtown Racks are bolted to two parallel rails which can be left freestanding or anchored to the ground. Rails are heavy duty 3" x 1.4" x 3/16" thick galvanized mounting rails. Specify rail mount for this option.

Rack Angle:



90



45A



45B



60A



60B

OPTIONAL LEAN BAR



Add Lean Bar

Lean bar ensures rack meets ADA requirements for cane-detection

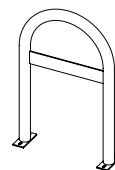

TAMPER-RESISTANT ANCHOR OPTIONS



Wedge Anchors (Not tamper-resistant with standard nut)

Zinc plated or galvanized steel. These are used for most surface-mounted bike racks going into concrete. To use these anchors, drill a 3" hole into concrete with a 3/8" bit. The anchor will expand as it is pounded into the concrete slab. It has a nut threaded onto the top of the anchor. When pounding in the anchor, keep the nut on, flush with the top of the anchor. This will help prevent pounding the anchor in too far. These are included with the cost of the rack. Stainless is available for an additional cost.



Breakaway Nut

These are aluminum cones with a six-sided nut that tears off once sufficient torque has been applied. What remains is a cone. They require no special tool, but cannot be tightened once the tearaway nut shears off.
\$2/each

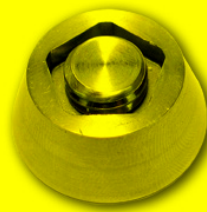

Penta Nut

If you wish to increase the security of your surface-mounted bike racks, consider the Stainless Penta Nut. Shaped like a cone on the outside, they are tightened with a five-sided tool that fits into the top of the nut. This is our best option. Pairs well with stainless wedge anchors (additional cost).

Tool: \$55; Nuts \$7/each



Concrete Spike

Zinc plated steel concrete spikes can be substituted for wedge anchors at **no additional charge**. Once installed, they are not easily removed, and cannot be tightened—they are like a nail. Stainless is available for an additional cost.



Triple Slot Nut

Also coned shaped, the Triple Slot Nut has three vertical slots requiring the tool to tighten and loosen. Made of zinc plated steel, they are a less expensive alternative to the Penta Nut. The slots are shallow, and not recommended for repeated tightening and loosening.

Tool: \$45.00; Nuts: \$1.00/each



DERO
A PLAYCORE Company

www.dero.com | 1-888-337-6729

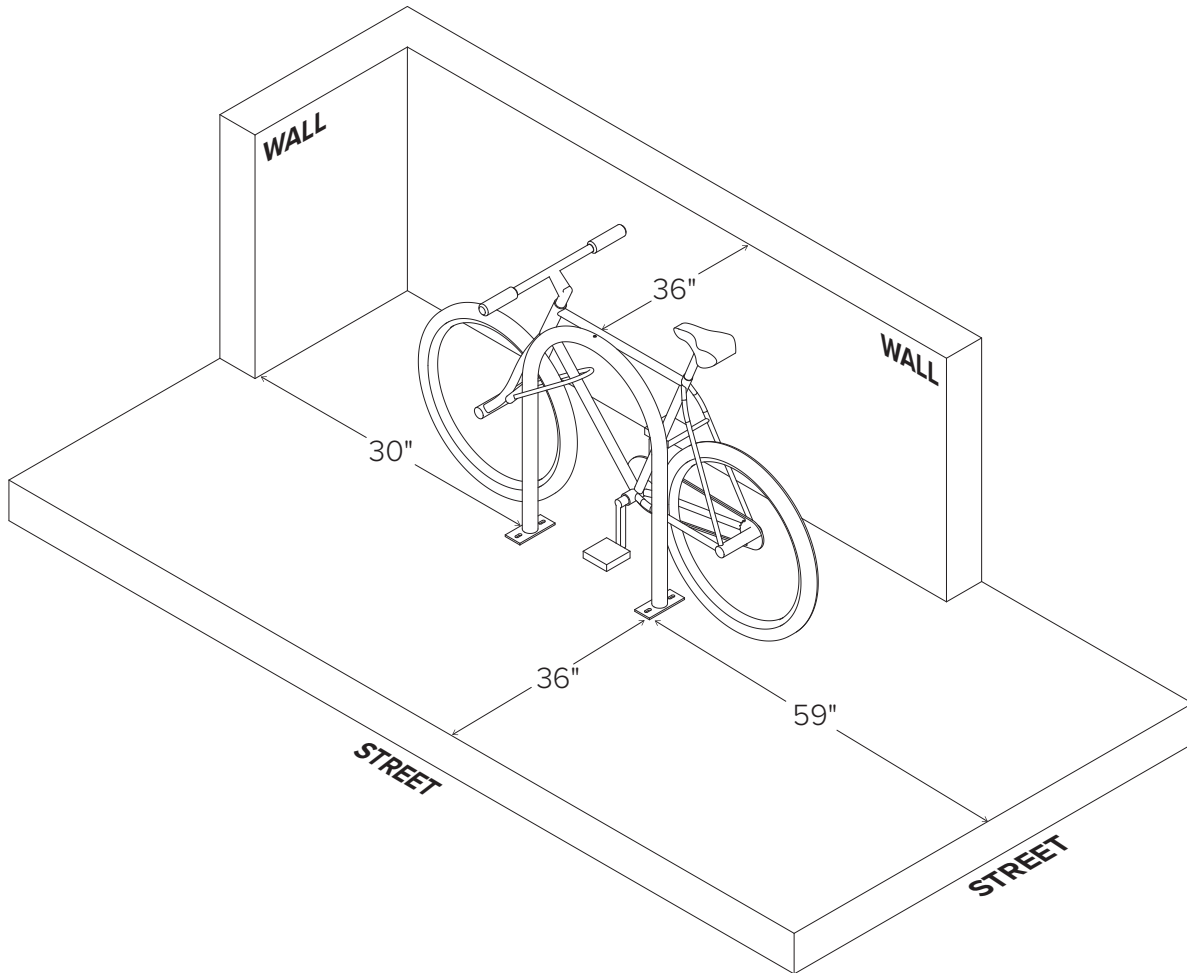

No Aisle

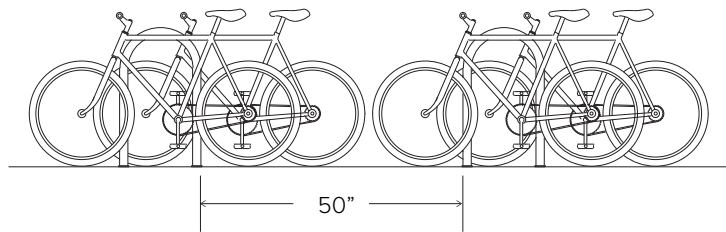

With Aisle

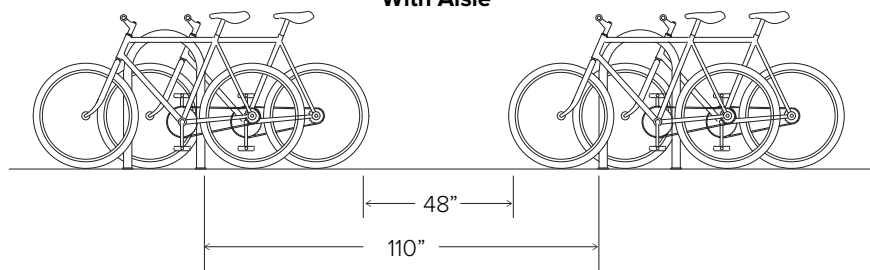



TOOLS NEEDED

- Tape Measure
- Marker or Pencil
- Masonry Drill Bit
- Drill (Hammer drill recommended)
- Hammer
- Wrench 9/16"
- Level

RECOMMENDED BASE MATERIAL

Solid concrete is the best base material for installation. To ensure the proper anchors are shipped with your rack, ask your Dero Rack representative which anchor is appropriate for your application. Be sure nothing is underneath the base material that could be damaged by drilling.

1

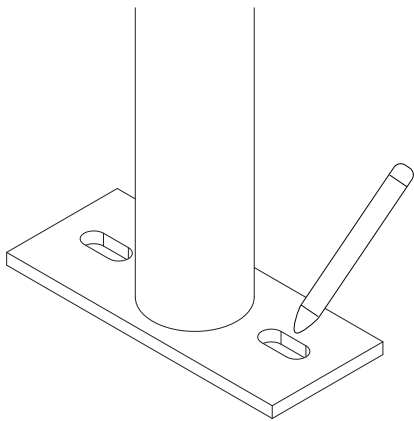

Place the rack in the desired location. Use a marker or pencil to outline the holes of the flange onto the base material.

2

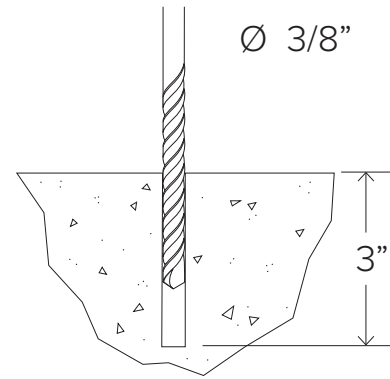

Drill 3/8" diameter holes 3" deep into surface. Make sure the holes are at least 3" away from any cracks in the base material.

3

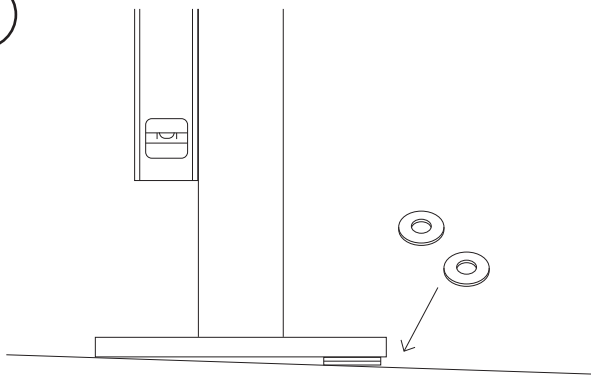

Place rack (and washers to level rack if necessary) over holes.

4

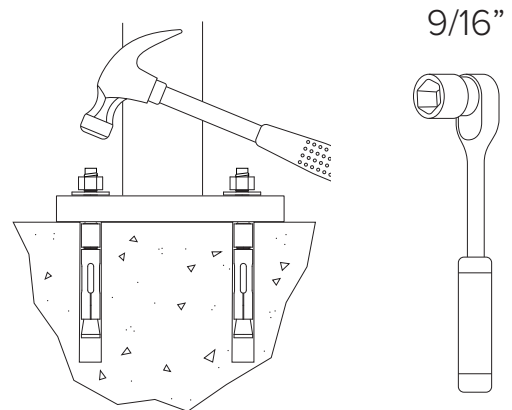

Thread nuts onto anchors, leaving approximately 1/4" of the anchor protruding, and tap into surface. Tighten nuts down to secure rack.



TOOLS NEEDED

Level
 Cement mixing tub
 Shovel

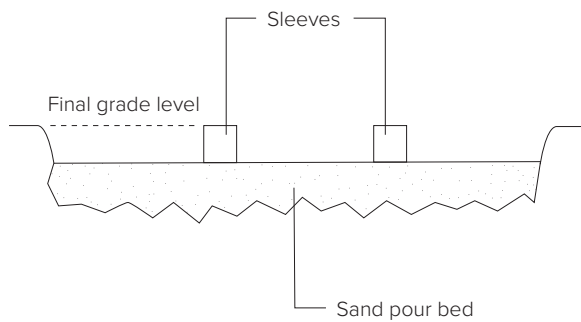
Trowel
 Corrosion-Resistant Sleeve (min. 4" diameter)
 Materials to build brace (see "Install Tip" at bottom of page)

1

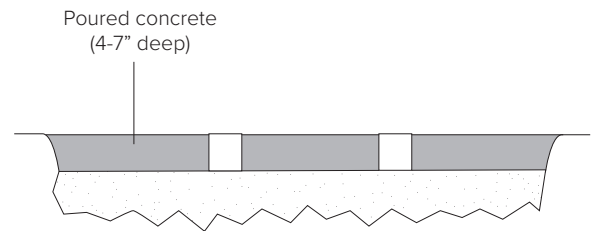
Place corrosion resistant sleeve (min. 4" inside diameter) in sand pour bed in exact location where rack will be installed. Make sure top of sleeve is at same level as desired finished concrete surface. Fill sleeve with sand to keep it in place and prevent it from filling with concrete.

2

Pour concrete and allow to cure.

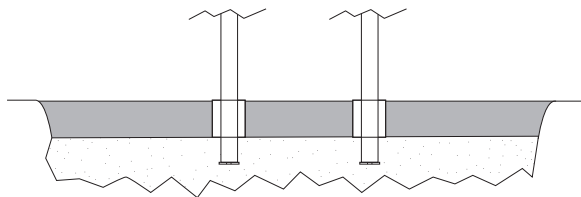
3

After appropriate cure time, dig out sand from sleeves and insert rack, making sure it is level and at the appropriate height. Pour in Super Por-Rok or epoxy grout and allow to set.

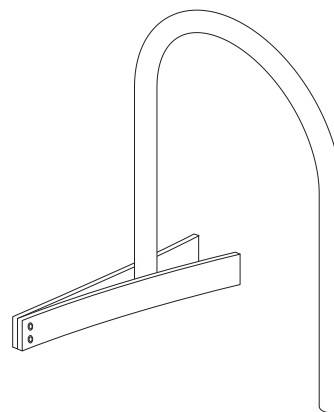
TIP

An easy way to brace the rack while the grout sets is to bolt two 1x4" boards together at one end and clamp them onto the legs of the rack like a clothes pin.



TOOLS NEEDED

Level
Cement mixing tub
Shovel
Access to water hose

Trowel
Hole coring machine with 4" bit
Materials to build brace (see "Install Tip" at bottom of page)

1

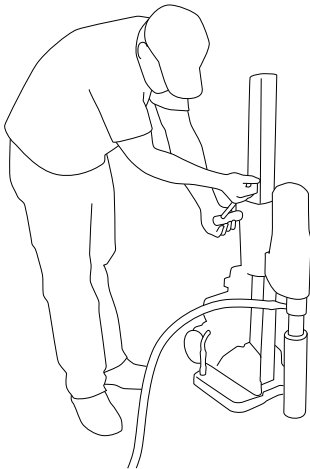

Ø 3" min.
↓ 10" min.

Core holes no less than 3" diameter (4" recommended) and no less than 10" deep into sidewalk.

2

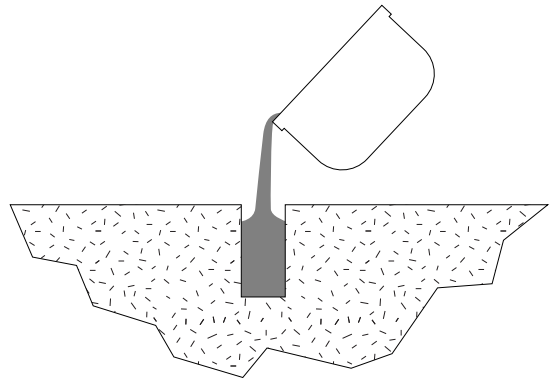

Fill holes with Super Por-Rok or epoxy grout.

3

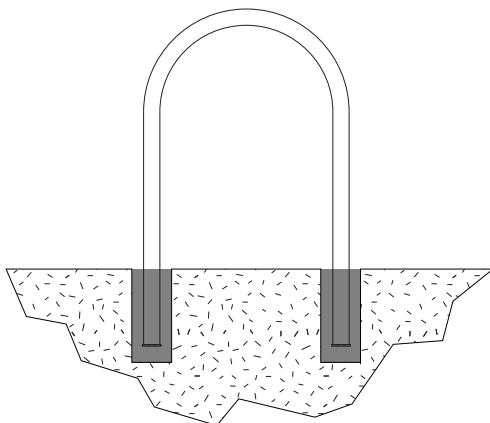

Place rack into holes, making sure it is level until the grout has set. 33"-36" of the rack should remain above the surface.

TIP

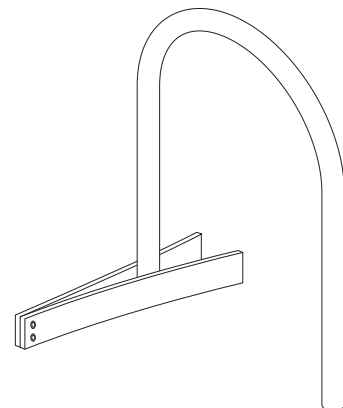

An easy way to brace the rack while the grout sets is to bolt two 1x4" boards together at one end and clamp them onto the legs of the rack like a clothes pin.

IN-GROUND MOUNT

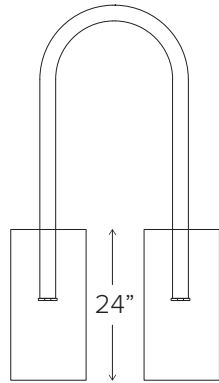
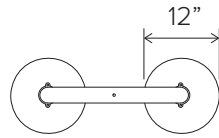

SURFACE MOUNT

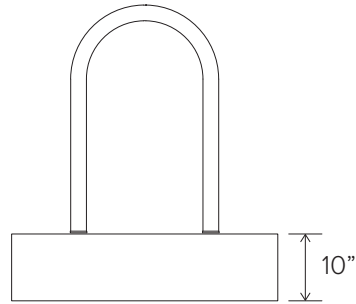
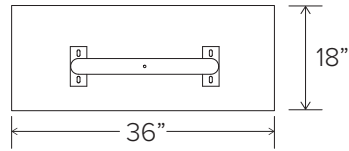

(or standard 4" sidewalk slab)