

PLAN OF COVER

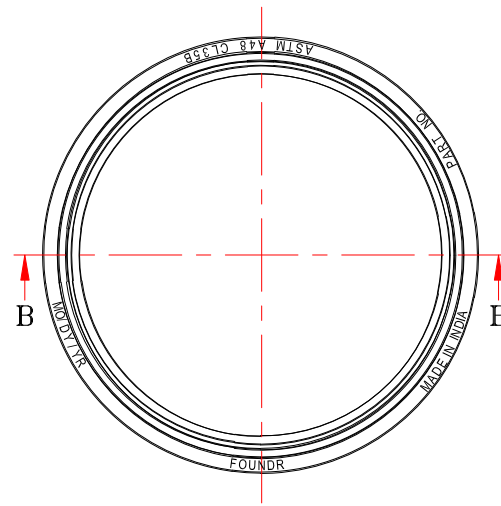

PLAN OF FRAME

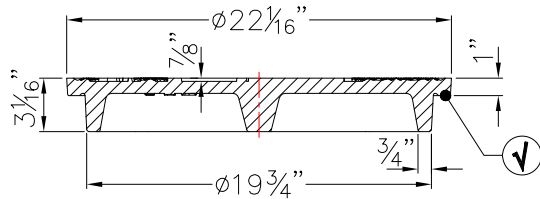

SECTION-AA

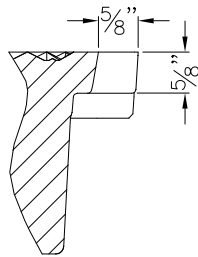

PICKHOLE DETAIL

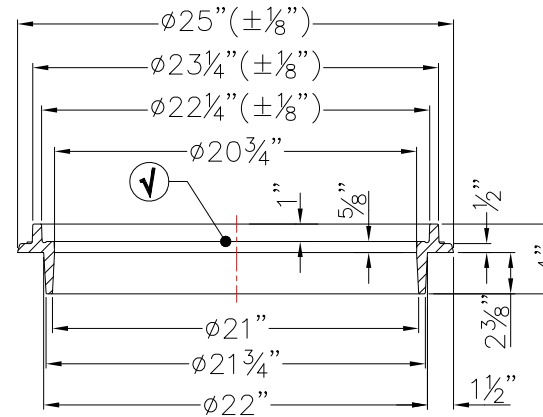

SECTION-BB

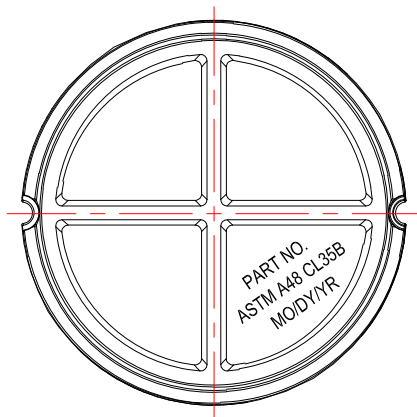

BACK OF COVER

R.#	REVISION	DATE	R.BY	APR
<b>R. B. AGARWALLA &amp; CO.</b> 2/6, SARAT BOSE ROAD, CALCUTTA-20, INDIA				
TITLE: <b>C.I. M.DUTY MANHOLE FRAME &amp; COVER</b> C/O.- $\phi 20$ "DIA(DPW-OVERLAND PARK/KANSAS)				
DRAWN BY :- S.SARIFUL		DATE :- 09.03.17		
APPROVED BY :- BNA		DRG. NO.:- N2161-CSTSWR		

DIMENSION:- All are in inches.	MARKING:- Each Casting Shall be Marked with AASHTO M 306-04.	MATERIAL:- ASTM-A48 CL.35B.
FINISH:- Coating Shall be done As per Requirement.	MACHINING:- All bearing surface (v) shall be machined.	WEIGHT:- Cover-134 lbs. Frame-52 lbs.