

TRIANGULAR

SILT

DIKE™

*The better solution
to bale barrier,
silt fence and
rock check dams!*



Triangular Silt Dike™ Barrier

Designed as an easy installed, economical solution to bale checks, silt fence, and rock check dams the Triangular Silt Dike™ barrier is a positive solution to many construction site drainage & erosion problems.

Applications

- Ditch Check Dams
- Diversion Dikes
- Drop Inlet Protection
- Temporary Ditch Liner
- Stream & Pond Protection

Advantages

- Effective
- Fast & Easy Installation
- Conforms to Curves and Rough Terrain
- Lightweight & Durable
- Re-useable



Distributor / Dealer:

A.S.P. Enterprises
Kansas City Office
800-519-2304

Triangular Silt Dike™ Barrier Installation

Made with lightweight and durable materials, Triangular Silt Dike™ barrier weighs just 7-9 lbs. per seven foot section and installs in minutes with U-shaped wire staples.

The flexibility of the barrier allows it to be installed on rough and rocky terrain while the protective aprons on both sides of the barrier helps prevent erosion and failure of the structure.

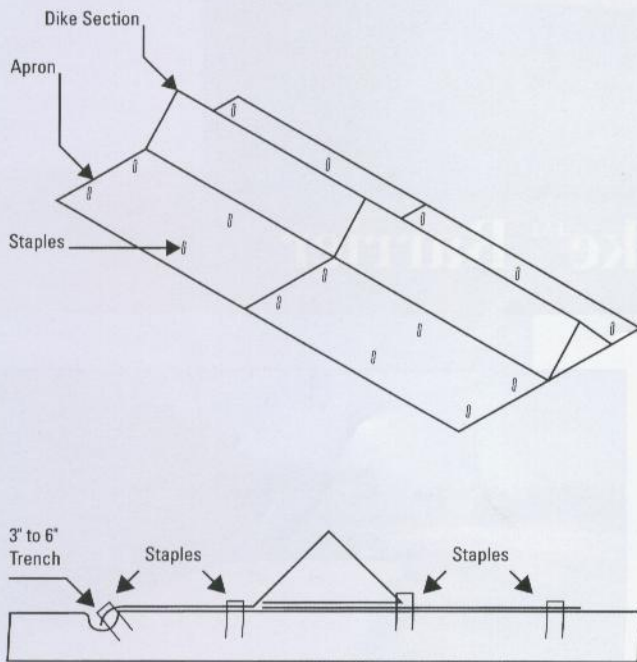

1-800-290-8473

www.tri-siltdike.com

Manufactured by:



US Patent No. 5,605,416

Triangular Silt Dike and the logo are trademarks of the Triangular Silt Dike Co., Inc.

