

PLAN VIEW

1 1/2" RAISED LETTERS

2 NOS. PICK HOLE

1 1/2" RAISED LETTERS

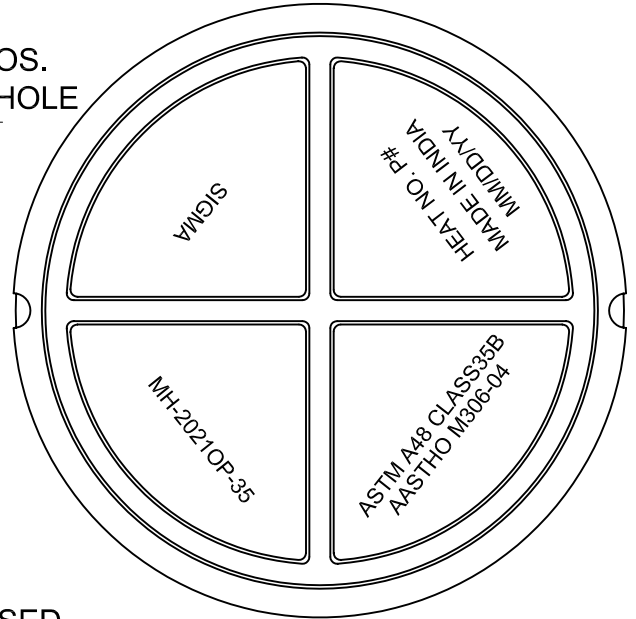

BOTTOM VIEW (COVER)

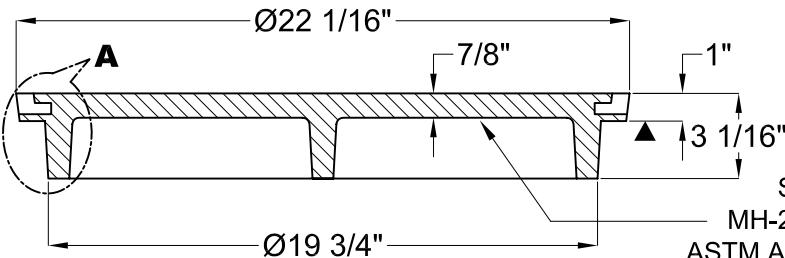

SEC. X-X (COVER)

SIGMA
MH-20210P-35
ASTM A48 CLASS 35B
AASTHO M306-04
MADE IN INDIA
MM/DD/YY
HEAT NO., P#

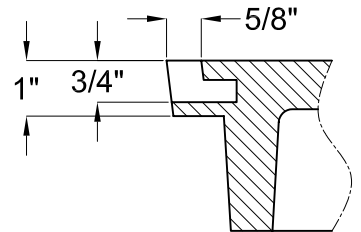

DETAILS OF 'A'

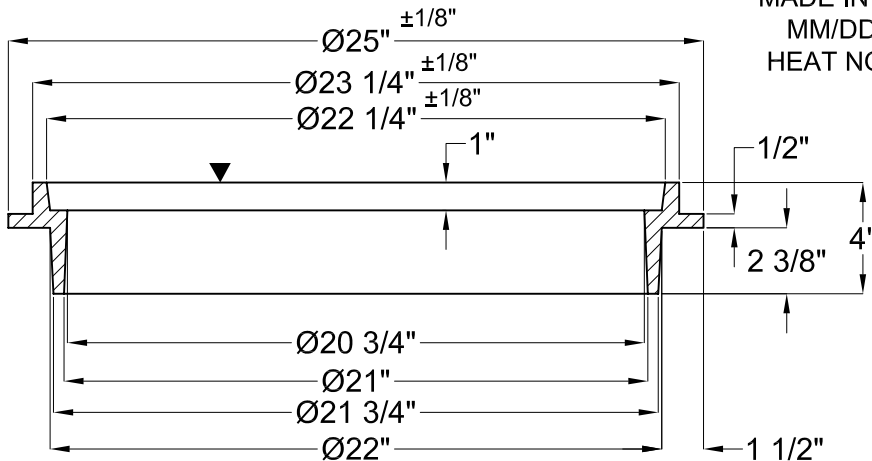

SEC. X-X (FRAME)

MH-20210P-35-- 135 LBS.
MH-2022-35-- 50 LBS.

TOLERANCE SHOULD BE ±1/16", UNLESS OTHERWISE SPECIFIED

<p>MATERIAL: Cast Iron ASTM A48 Class 35B Meets H20 Loading Standards As per AASTHO M306-04</p>		<p>DESCRIPTION: CITY OF OVERLAND PARK WITH 4" HIGH FRAME + COVER MARKED WITH STORM SEWER</p>			<p>REV.- "0"</p>	
<p>COATING: PAINTED/UNPAINTED</p>						
<p>DRN. BY: 23.02.10 B. DUTTA</p>	<p>CHECKED BY: ASHIS DEY</p>	<p>WEIGHT: 185 LBS. (SET)</p>	<p>ISSUED ON: 23.02.10</p>	<p>APPVD. ON:</p>		