

17.0 Bridge Design

17.1 Field Check

Plan details for the field check portion of the design process are intended to familiarize our offices and departments with the site before physically visiting the site. The components discussed below are necessary elements of the skeleton of the final project plans. The onsite field check meeting to discuss important details of the project will produce a strategy for the remaining design of the project. This strategy will be enhanced depending on the amount of information provided to BLP in the field check plans. This section explains the bare minimum of what to include on each sheet required for Field Check Plans. If, however, more information is available to the consultant, additional sheets and additional design information may be added to aid in better describing the overall project site, and aid in the cooperative effort of developing the final set of design plans.

17.1.1 Bridge Plan Assembly

For all bridge length structures, the field check plan should contain, as a minimum, a Contour Map, a Construction Layout at the site of the structure, and a Typical Section of the proposed bridge(s). As a typical drafting standard, the text on each sheet should be readable from either the bottom of the sheet or the right side of the sheet. As a rule of thumb, field check defines the point where the plans should be approximately 50% complete. However, the total of the bridge sheets may be at only 15-20% complete. The probable structure has been decided upon, with span lengths and location of the structure decided and the design of the structure itself has advanced. Once this has been confirmed at the field check meeting the last major aspect, investigating geology, can be organized to allow the design of the structure to progress to final stages. The three primary sheets necessary for field check plans will be mostly complete by the time of submittal.

A fifteen digit structure ID is required for every bridge-length structure on the local system. The existing structure ID must be retired and removed from the National Bridge Inventory (NBI) if the structure is replaced. A new structure ID must be assigned (by BLP) to any newly constructed bridge-length structure. If a particular number is desired by the owner in order to maintain their own numbering system for new bridges, this number must be decided upon and communicated to the consultant before Field Check Plan submittal. If the desired number is not on the Field Check Plans, or no particular number is desired by the LPA, a number will be assigned and reserved by BLP Bridge during the Field Check Review stage of plan development.

17.1.2 Contour Map

Using data compiled from a recent survey, the plan sheet contours should be plotted at 2'-0" intervals in most cases. The typical scale for a contour map will be 1" = 50'. Include a simple line sketch elevation view of the existing waterway opening (and any adjacent structures) with substructure elements depicted, along with station and actual elevation or relative elevation of pertinent features such as bottom of streambed, top of opening, etc.

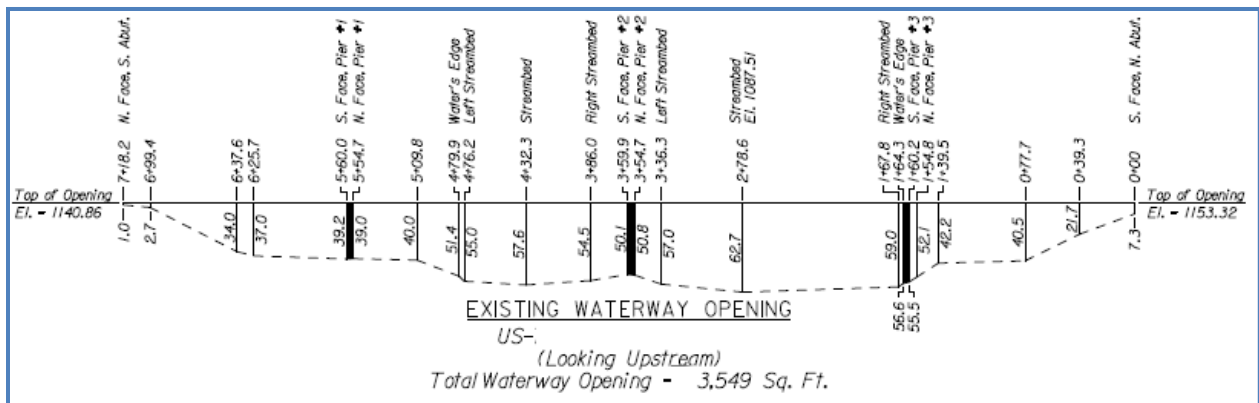

Plan view will include:

- At least two P.O.T. references
- Centerline curve data if applicable
- Centerline with stations above or to the right
- Section, township, and range with property owner information
- Type of land use
- Any structures, fence lines, drainage structures, etc.
- Location, type, and size of utilities and owner information
- Stream name and direction of flow
- Existing right-of-way and existing easement(s)
- Contours at 2' intervals
- Existing road, path or rail and all existing structures
- Proposed improvements, right-of-way, easements, Construction Limits
- Proposed Structure
- Proposed channel changes or improvements with stationing, elevations and line sketch of proposed typical cross-sections
- Shoofly Detour Alignment and structures, if applicable
- If possible, indicate where historic high water elevation was established
- Standard North arrow with selected scale of the sheet

This sheet will also include notes/callouts for "Remove" and "Construct" as appropriate for the Existing and Proposed structures. The station at centerline, the old and new fifteen digit structure numbers, and a short

bridge description (with the four character structure designation) should be included along with the Demolition Category and Erection Category for the corresponding structures. If no Erection Plans are required by KDOT Specifications it is recommended the designer state "Erection Plans Not Required" instead of the Erection Category. There are some structures KDOT Specifications do not require to have Erection Plans, but do require falsework plans. "Category (X) Falsework" within the "Construct" callout is recommended in this case.

@ Sta. 60+78.25 Construct Br. No. 55' - 2 @ 70' - 55' Continuous Composite Weathering Steel Welded Plate Girder (WWCC) Spans 40' Roadway Erection Category A	@ Sta. 60+40.00 Remove Br. No. 60' - 2 @ 80' - 60' Continuous Low Steel Truss (SLTC) Spans 26' Roadway Demolition Category A
or No Erection Plans Required	

Several notes pertaining to the removal of the structure may be needed. If the structure is steel and may have paint containing lead, this needs to be clearly stated on the contour map, as well as on any other sheets involving removal. Disposal of this material will fall under the contractor's responsibility if there is no salvage on the part of the county. If there is conclusive evidence or testing has indicated use of lead paint on the existing structure, state this in a note on the sheet. The LPA may wish to salvage part of the existing structure so a note should specify what elements will be salvaged, where it will be stockpiled, and who will remove the material from the site. If the LPA does not wish to salvage any part of the structure, it is recommended to place a note stating the same so the issue is clearly addressed and dismissed, or simply include the information in the note specifying the contractor will remove the existing structure and remove the material from the site and the county does not wish to salvage any part of the structure. The decision to salvage material from the existing structure may not have been made before the field check meeting, so this information is only required on the sheet once the Office Check Plans are submitted.

Any "critical path" notes should be placed on the sheet to aid in the overall construction plan. For example, if a channel change or channel improvement is required on a proposed project with limited headroom under the structure, or if special bridge spill slopes and slope protection are to be constructed at the site, a note stating the Grading Contractor is required to excavate and complete the channel or spill slopes prior to construction of the Bridge should be included.

If the location of the historic high water elevation was established as a general observation similar to "the bridge overtopped in 2009 by approximately 1 to 2 feet according to local residents," place a note stating the same on the Contour Map. If a known elevation is achieved using visible drift, or high water marks, indicate the location on the Plan View and include a note stating how the elevation was established.

17.1.3 Construction Layout

The sheet should be at a larger scale as compared to the Contour Map so additional detail can be seen, detailed and dimensioned. 1" = 20' is a typical scale used for the sheet, but may be increased if needed for easier dimensioning and labeling. This sheet will detail and dimension a plan view of the structure and an elevation view of the structure along with various pieces of information pertinent to the structure and construction site characteristics.

17.1.3.1 Plan View

This view will typically include contours at 2'-0" intervals similar to the Contour Map sheet. If the site is fairly level and due to the increased scale, as compared to the Contour Map, 2'-0" intervals may not display enough detail so the interval may need to tighten to 1'-0". Indicating direction of flow for streams and railroad ditches is also required, if applicable. Always include a standard North arrow with the selected scale on the sheet. The increased scale will allow better detail on location and size of any utilities on site. Owner's information will be clearly stated for each utility line.

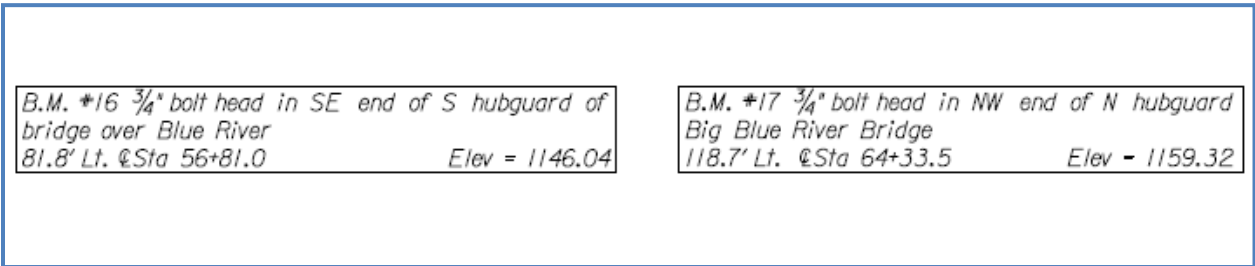

The designer should attempt to show a minimum of two benchmarks within the plan view limits, preferably on opposite sides/ends of the structure. If the increased scale prevents locating the benchmarks on the plan view on the sheet, describe the locations and state the established elevation. The reference datum description typically placed on the first Plan and Profile sheet will likely need to be repeated on the Contour Map and Construction Layout sheets to simplify the process if the bridge sheets are separated out from the rest of the plan sheets for subcontractors' uses.

Centerline Project and Baseline should be clearly indicated. Stationing along project centerline should be shown in proportion to the project limits. Existing streambed and proposed streambed (and stationing) is to be clearly defined as well as the name of the stream and the flow direction.

Proposed foundation types and locations should be shown to aid in the geology investigation. Occasionally the project scope does not support the need for a separate Geology sheet so the information provided by the final Geology Report will be placed on the Construction Layout sheet after the investigation.

The extents of any slope protection, shot rock, gabions, drip lines, walls, or other proposed structures should be shown on the layout graphically with macro dimensions. Any necessary typical sections of these structures to depict geometric details should also be shown if the same structures are not examined on additional sheets. Additionally, any channel improvements need to be detailed within the plan view along with section views of the improvements for construction purposes.

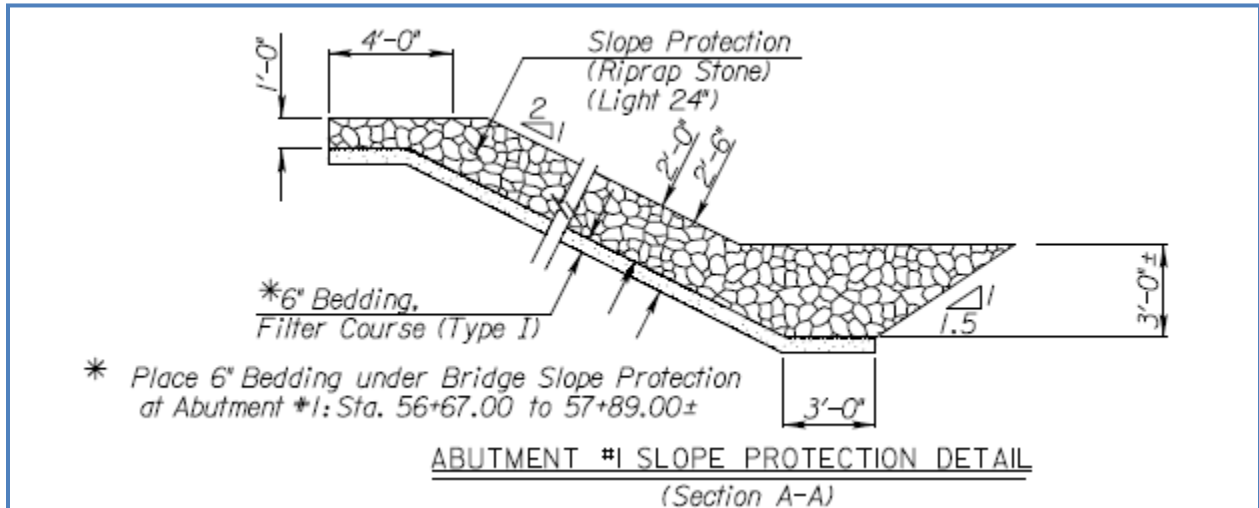

The structure information in the plan view will include span dimensions from bearing to bearing, stationing, callouts for the approach slab sizes, lane and shoulder width dimensions on each end of the structure, total roadway width on the structure, plan thickness dimension of the rails or barriers, cross-slope grades on each side of Crown Grade, inside face of rail or barrier to Crown Grade dimension on each side of Crown Grade, Crown Grade offset from Centerline dimension (if applicable), bridge berm dimension at each abutment, and location of any number plate or plaque (if applicable)(number plates or plaques are non-participating items). Limits of slope protection at each abutment is also shown in the plan view both graphically and dimensionally, if the entire limits are able to fit within the trimmed view of the structure at the increased scale.

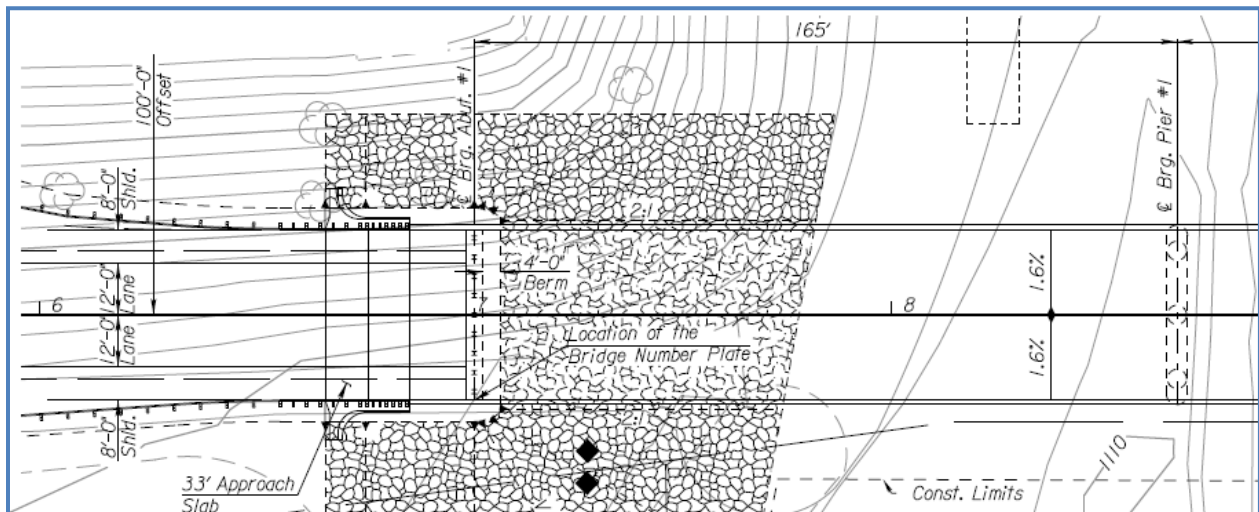

17.1.3.2 Elevation View

The elevation view provides a macro-view of the proposed structure and the foundation elements. It is important to modify the scale for both plan and elevation view in order to accomplish the level of detail necessary on the sheet. The elevation is typically a longitudinal section at the Centerline or Crown Grade of the structure. All stations and top of deck elevations will be taken at the Crown Grade, Profile Grade or Centerline of the structure depending on the complexity of the structure and the designer’s preference. It is useful to include the graphic representation and possibly dimensions from the nearest new foundations to the foundation elements of the existing structure as information the bridge contractor may need in preparing a bid.

Each End of Wearing Surface (EWS) and Centerline (CL) bearing will be labeled with an element number (Abutment 1, Pier 1, etc. if applicable), station to the nearest 0.01 foot, and elevation for top of deck to the nearest 0.01 foot. The elevations will be labeled according to which project line is used (Cr. Gr., Pr. Gr., etc.). Dimension individual span lengths, the remaining distance between centerline of abutment to EWS, as well as the entire EWS to EWS length.

Callout the grade of the roadway, if constant, or simply label as Cr. Gr. VC or something similar and provide a line sketch of the vertical curve near the elevation view. This sketch should contain a not-to-scale graphic of the vertical curve including all pertinent curve information graphically or in a small table as well as the bridge location shown on the graphic. Horizontal curve data, if applicable, should also be stated on this sheet for further discussion during a field check meeting.

Elevations for this view include Crown Grade (or Profile Grade) at each EWS and each substructure element at centerline of bearing, top of pile or top of shaft, top of berm, and various hydraulic elevations including ordinary high water, design high water, historic high water. Also include the clearance dimension to low structure from design high water.

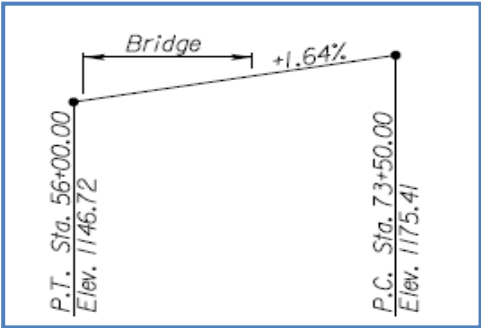

A preliminary Hydraulic Assessment Checklist (HAC) will provide the information required to fill out a standard Drainage Data note. The correct drainage data note will need to be on the plans with the data filled in from the HAC. The data required to be on the final plans changes occasionally, so it is necessary to use the latest electronic HAC and the latest standard note available from the KDOT website. The HAC also contains a sheet to enter scour information. This is generally the same information necessary for Item 113 data. Since Item 113 has now been assessed for virtually all structures on the local system, it is suggested to perform the necessary calculations (or perform the electronic model analysis for scour) and enter the data on the HAC so the data is available for the Item 113 Justification form.

17.1.3.3 Typical Section

A typical section is required for each proposed structure, and is very useful to have prepared for the Field Check plan stage. The complexity of the structure determines how many “typical” sections may be required in the final plans. The purpose of the typical section sheet, in the final plans, is to display typical dimensions, vertical and horizontal spacings, reinforcing steel sizes, cross slopes, bearing types, elevations and to indicate stations of the changing “typical” section in more complex structures. For purposes of Field Check, the typical section is used to depict a rough approximation of structure type and size with macro dimensions, proposed rail type and size, deck type and thickness, and proposed cross slope of the structure. A typical section can be included on another sheet if the structure is reasonably simple. For example, a RCB standard drawing includes the elevation view of the structure, the typical section of the structure, and the bill of reinforcing for the box all on the same sheet. The simplicity of this type of structure dictates the simplicity of the typical section.

As structures increase in complexity, the typical section sheet(s) needs to display more information. If the structure is a relatively basic open span bridge the typical section may include a section near mid-span, and one near an interior support, or a half section at an interior support with the other half depicting the section at mid-span.

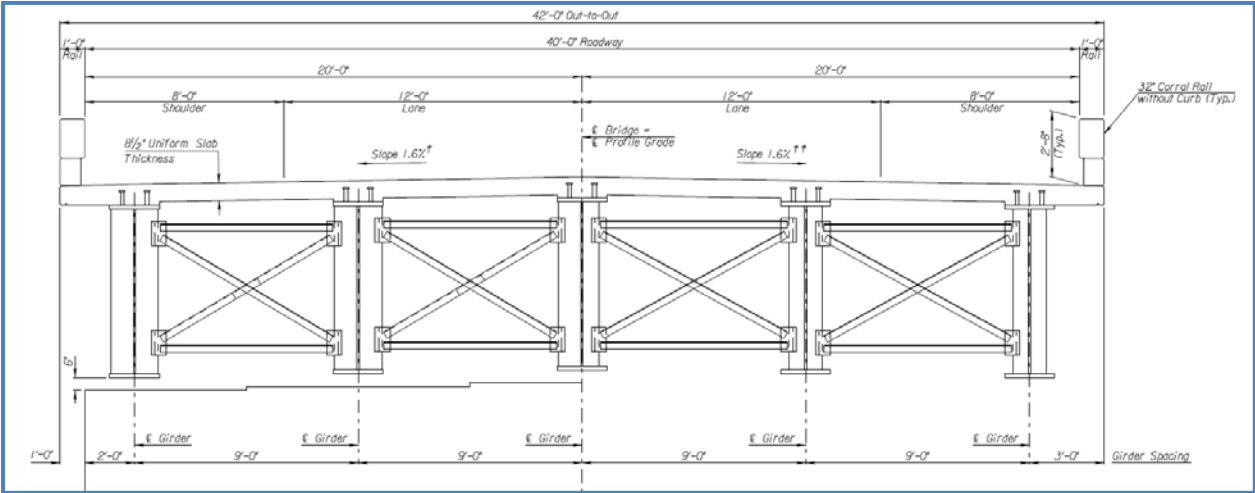

17.2 Office Check

Plan details for the office check portion of the design plans concentrate on preparing the remainder of the sheets to explain the details and specifications of the designed structure. The components discussed below are the necessary elements. The field check plan review and onsite field check meeting addressed changes necessary to the first submittal and the corrections are assumed to have been resolved by discussion or added/corrected. Confirming the Field Check plans allows for the geology investigation to take place in order to furnish that information to the designer for the remaining design of the structure. This section explains the minimum of what to include for Office Check Plans (See [Section 5.5](#) in this Manual).

17.2.1 Bridge Plan Assembly

The Office Check Plans should contain, as a minimum, a completed Contour Map, a completed Construction Layout (with geology information if a separate sheet is not included), a General Notes and Quantities sheet (if applicable) and various structural detail sheets depending on the complexity of the structure(s) as well as the many standard drawings necessary for a KDOT let project. Office Check Plans should be approximately 95-99% complete. The structure has been designed and detailed, foundations types, sizes and lengths (depths) have been calculated and detailed, berm slopes are finalized for size and grade, and the final type, size and thickness of any protection measures have also been detailed. If the project necessitates any temporary structures, these structures are also fully designed and detailed at the time the Office Check plans are submitted.

17.2.2 General Notes and Quantities

Any structure more complex than a reinforced, concrete box will have a General Notes and Quantities sheet. This sheet will incorporate standard notes and standard bid items into the project as the first sheet concerning bridge size structures. All standard notes and standard bid items are available from KDOT's website. The standard notes often contain language such as "KDOT bridge office," "State Bridge Office," "SBO," or something similar in reference to where different item submittals should be sent. This language will necessarily change for a local project which has consultant oversight of design and construction in place of state oversight. It is also important for the Inventory and Operating load ratings for the standard LRFD and LFD trucks to be entered into a standard load rating table and placed in on this sheet.

"Plan Review Summary Information" (Appendix) is a reference to typical notes used when different types of work will be encountered. This is not an exhaustive list as requirements are removed, updated and added frequently. However, the reference does provide the designer with a rough framework to find most of the required notes.

17.2.3 Contour Map

Review the requirements within the Field Check section for the Contour Map. Any missing or unknown information at the time of Field Check should now be on the sheet. Particularly, salvage information and any critical path items should now be known and notes placed on the sheet.

17.2.4 Construction Layout

Any required hydraulic/drainage information will be used to fill out the final HAC. The information from the HAC will be transferred onto this sheet in the appropriate note.

Kansas Department of Transportation, Design Manual Volume I (Part C), Road Section, Elements of Drainage & Culvert Design, July, 2008 Edition, Table 10.4-1 gives the Guidelines for Design Recurrence Interval (<http://kart.ksdot.org/Download/DownloadDetail.aspx?FileID=230>) then states the following:

“These guidelines should be applied to the extent practicable for new and existing highway drainage structures. On highway reconstruction or replacement projects, where existing facilities and right-of-way often dictate highway profiles, it may not be feasible to meet these guidelines. In such cases, the designer should endeavor to provide the highest degree of protection that is cost-effective under the existing circumstances. Federal, state, or local floodplain ordinances requiring a greater degree of protection may take precedence over these guidelines.”

Additionally, the KDOT Bridge Design Manual states:

“...the true design frequency is the frequency flow which overtops the roadway and puts it out of service, or it is the frequency which satisfies the requirements of the allowable water surface elevations.”

In a sag vertical alignment where there is no overflow area, the design frequency will be equal to the frequency that will still provide the freeboard decided upon at the field check meeting. Where an overflow area is provided, the design frequency is the frequency that takes the bridge out of full service, or simply at the frequency the road overtops. However, if a Q25 design is all that is necessary for the classification from Table 10.4-1, and Q25 does not overtop the road or even approach the required freeboard, the designer does not typically need to calculate larger frequency intervals unless it is required by other specifications/agencies.

This sheet will now show the location of all Test Pile, both in the Plan View and Elevation View. All pile will be labeled, number and length, at each substructure in the Elevation View. Test Pile must be called out separately due to the additional ten foot of pile length required to perform the PDA test.

Berm slopes are typically 2:1. The slope may be slightly adjusted as needed for the site conditions and soil conditions. Some type of slope protection is common either along the drip lines of the structure, or protecting the entire slope to prevent erosion from stream flows. The information needed to decide the thickness and size of the slope protection will have been provided from the hydraulics analysis and the

geology report for soil types. For stream crossings, typically the bottom of the toe of the slope protection will need to be above the ordinary high water elevation. If the slope protection is carried down to the streambed at a 2:1 slope, this necessitates longer structures, and creates a lower “channel” on either side of the real streambed. Creating two ditches of slope protection on either side of the streambed elevation is not an acceptable practice from a design standpoint, or an environmental agency standpoint. Below is an example of bridge berms with slope protection and a special toe. The toe does pierce below the Ordinary High Water elevation, but the rock is located well removed from the streambed and is “protected” by a fair amount of in-situ streambed material. This design keeps the stream within the natural stream channel during normal flows, and during higher frequency events the berms are protected from erosion. The existing banks are cut horizontal at the OHW elevation and the design does not create “ditches” on both sides of the streambed during normal flows. A designer could also make the decision to protect the horizontal cut to the edge of the natural channel to incorporate some scour protection around the piers, but all riprap would still be above the OHW elevation which is much more acceptable from an environmental agency viewpoint.

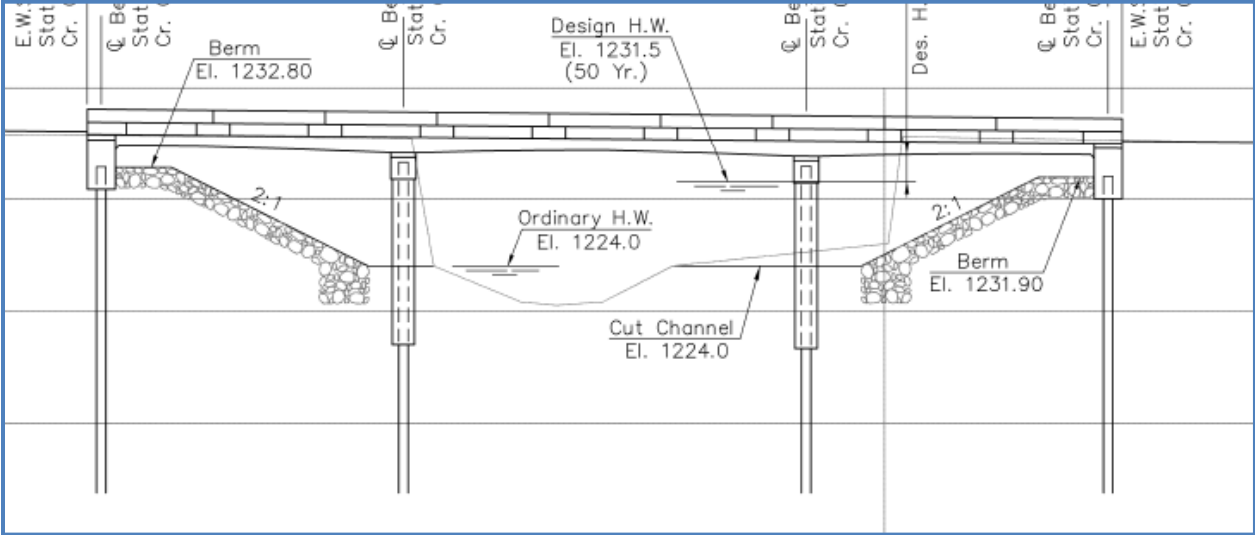

For grade separation structures, the berm slopes will be protected as determined by analysis and any open ditches which convey drainage through the structure will need to be maintained with the ditch bottoms receiving a minimum of a two foot thick riprap lining.

Minimum horizontal and vertical clearances, ditch widths and lane widths must be in accordance with the appropriate specifications given the type of traffic on the bridge and, if applicable, the type of traffic being spanned by the structure. Dimension required clearances on the Plan and Elevation Views.

17.2.5 Geology

If a structure is complex a separate geology sheet may be required. A typical geology sheet contains a simplified plan view with structure dimensions, dimension and spacing of foundation elements, and the type and location of any geology investigation holes (core hole, power auger, air hammer, etc.). The simplified

elevation view of the structure typically contains only stations of the foundation elements, top of pile or shaft elevations, and the data gathered from the geology investigations, as well as the various geology layers which occur beneath the structure laid out in a matrix of stations vs. elevations.

A probe investigation of a proposed bridge-length culvert is not recommended. If only a probe investigation is done, it must be supported with recorded geology within a reasonable distance of the project site. It is recommended every bridge-length box have a geology boring performed (with SPT testing, Cone Penetrometer, or some type of similar testing done to quantify subsurface conditions) at CL of roadway CL proposed structure (or at a location as close as reasonably possible to CL-CL).

The Contractor Furnished PDA bid item (page 17-14) is used when driving test pile is desired at the site to verify the “generalized” geology information and to maximize pile resistance. In order to maximize the design capacity of the production pile versus the cost of the Contractor Furnished PDA Section 10.5.5.2.3 in the AASHTO LRFD Bridge Design Specifications should be considered. Again, the location of the test pile must be designated on the plan view (and elevation view) on the Construction Layout sheet and restated on the separate Geology sheet, if applicable.

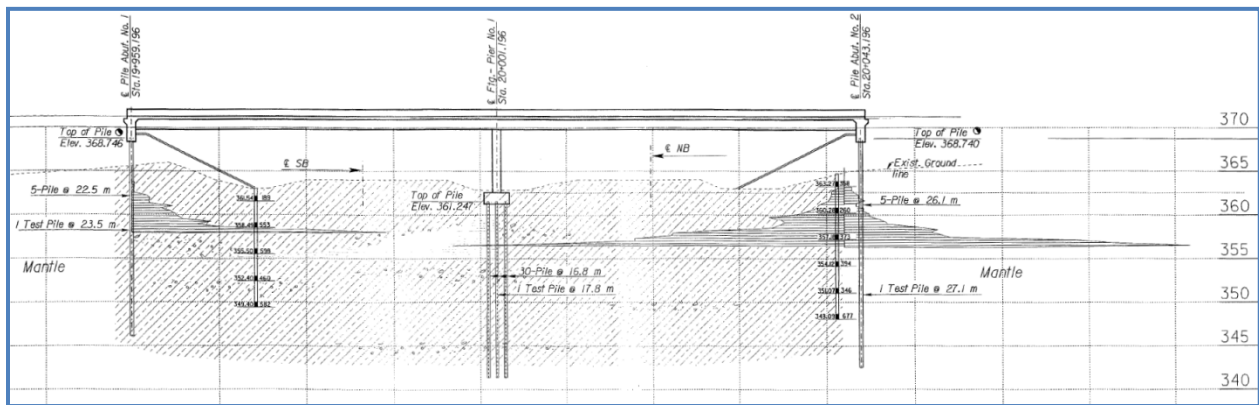

17.2.6 Typical Section

More complex girders, bar patterns, or structure geometry can lead to several “typical” sections. For example, if a structure transitions from a full-super to a normal cross-section across the length of the bridge a typical section would need to be shown at the station of “full super”, at the station to start the super-transition, at the station the super reaches +1.6%, +1.6%, the station where 1.6%-0.0% is achieved, and where the normal cross-section (1.6%, -1.6%) occurs. If a site necessitates odd span arrangements the bar patterns may be different across the changing span lengths, so the typical section would need to address these types of changes in some fashion.

For a more common alignment, or more simplistic structures, the typical section at field check displays macro dimensions of major superstructure elements. In the Office Check plans, the typical section will show a greater amount of detail for superstructure components. Longitudinal reinforcement size and spacing at mid-span and at supports, transverse reinforcement, clearance dimensions, cover dimensions, location of

drip grooves, rail dimensions and various other details will be displayed on this sheet as well as the macro dimensions of the major elements.

17.2.7 Framing Plan

For span structures incorporating steel/concrete girders or beams, a framing plan is required. The framing plan is a layout of the entire skeleton of the superstructure which shows permanent and temporary diaphragms to be used during erection, labels of each girder/beam, bearing locations, and bearing stiffener desired locations after erection of the girders/beams. Several elevation views and section views at supports/bearings to aid in girder/beam erection process are useful for construction inspectors to verify the final conditions are as the designer intended.

17.3 Final Check

The label “Final” expresses the nature of this plan submittal. The Final Plans will be complete. All suggestions need to have been addressed in some form by the time Final Plans are submitted. All comments which have been made by BLP on previous submittals are made to improve the plans by suggesting changes, or requiring changes. If corrections are not made, the review process is not efficient nor is it effective. All required corrections must be made by the Final Check Plan stage. Any suggestions made by BLP need to be addressed. Suggestions and comments by our office do not override design decisions made by the designer or the owner, but the reasoning behind the designer’s or owner’s choice to disregard the suggestions needs to be communicated. Without communicating the reasoning behind dismissing a suggestion, the reviewer is left to wonder if the suggestion was overlooked or simply ignored.

As major portions of the plans have been reviewed, the reviewer will often focus on suggested corrections, or newly added details or sheets. As the plans progress, if a detail has been reviewed and is in no need of modifying, that detail typically receives only a cursory review on successive submittals. Since this occurs to speed along the review process, the designer should make no changes to details which have not been highlighted as needing corrected between Office Check submittal and Final Check submittal without drawing attention to those changes. Explain the modification, addition, or deletion to the project manager, email the reviewer, or highlight the modifications on the plan sheets in some manner to draw attention to the added detail, or minor modification of a note, dimension, or something similar. By Final Plan submittal, the reviewer is primarily looking for corrections taking place from what was suggested on the Office Check plans. Draw attention to any elective changes made by the designer which the reviewer did not suggest on the Field Check, or Office Check plan sheets.

Minor corrections, quantity modifications, erosion control items, or perhaps incorrect details which may have been missed during previous reviews will likely be the only changes left to be made to final check plans. The PS&E plan submittal will be inclusive of all the noted changes from the previous review. For information see [Section 9.0 PS&E](#) in this Manual.

17.4 Post Design – Post Construction

17.4.1 Item 113 – Scour Vulnerability

Item 113 Scour Vulnerability is an inspection item based on the design of the structure with regard to scour. As a new NBI Structure ID is added to the database item 113 is assigned a rating of 6 – Scour calculations/evaluation has not been made. A scour assessment of the bridge site needs to be carried out for all open span structures and three-sided culverts with deep or shallow foundations if the material under the structure is erodible. Shallow footings keyed into rock would not need an analysis carried out. However, for every structure type the Scour Vulnerability sheet needs to be completed.

17.4.2 Load Ratings

Load Ratings must be calculated for any new structure. The Inventory and Operating load ratings for the standard LRFD and LFD trucks must be entered into a standard load rating table and placed in the plans (typically on the General Notes sheet). The Load Rating Summary Sheet is required to be filled out for all required rating trucks and placed in the bridge file maintained by the LPA. The Load Rating Summary Sheet, the Rating Model, and the design plans which are all developed by the design engineer should be modified with regard to the construction of the bridge to account for any construction modifications or errors. One example of a construction modification which would be necessary to document on the “As-built” plans would be if bearing for all steel pile was achieved 4-5 feet above or below anticipated pile tip elevations. Another would be if the inspector inadvertently used the wrong bearing values to drive to during the pile driving operation and all pile were driven to a bearing 10-15% less than what was specified on the plans. These are small bits of information which could be vital in the future for a bridge widening, or an analysis of the structure in terms of scour.

17.4.3 Load Rating Summary Sheet

The Load Rating Summary Sheet (LRSS) shall be filled out in its entirety and placed in the LPA’s bridge file. For all structures constructed after October 2010 the LRSS needs both an LRFR and LFR rating. Any structures built before this date require only an ASR or LFR load rating depending on the year and design of the structure. Again, this is a Rating Summary, not a posting summary.

17.4.4 Standard Notes

The “Plan Review Summary” document (Appendix) lists specifications and notes to be reviewed if the project contains applicable items. As the table states, the specs and notes listed may only be the beginning template of the items to delve into at the outset of the project for the listed items.

Many of the standard KDOT notes contain language referencing “KDOT,” “State,” “State Bridge Office,” or similar entities. Some of these references need to remain as in the case of “...refer to KDOT Specifications...” however, when the language refers to KDOT as the oversight agency, or as the owner, these terms need to be modified to reflect the world of Local Projects. In a general sense the terms can be modified to “Owner” or “Owner’s Engineer,” but the designer will need to approach each note modification with a critical eye to assure the correct terms are modified and the note maintains the original intent.

Example:

*FALSEWORK INSPECTION: This project has falsework plan requirements which are considered “Category 2” by KDOT specifications. If falsework deficiencies or variations from the approved and sealed plans are found, the falsework design Engineer of Record will provide written approval of the changes. If for the convenience of the Contractor the falsework becomes “Category 1” by the use of non-typical supports; then the inspection and review requirement of “Category 1” will be fully enforced, but at no cost to **the State**. “Category 2” falsework inspection is not paid for directly, but is subsidiary to other bid items.*

The “Contractor Furnished PDA” bid item used by LPA’s to pay for what is normally referred to as “Test Pile” or “Test Pile Special” must be accompanied by the following note:

CONTRACTOR FURNISHED PDA: Use the Pile Driving Analyzer equipment at the locations shown on the Construction Layout. Use Pile Driving Analyzer equipment and methods compliant with KDOT Special Provision. The piling shall remain in place as permanent piling. Drive the piling to the resistance value of (Strength I divided by Phi).

At any location where problems are experienced, pile damage is suspected, or the Pile Driving Formula Load occurs significantly above the design pile tip elevation, the Owner's designated Engineer may request that the Pile Driving Analyzer (PDA) equipment be used.

17.5 Geotechnical Bridge Foundation Investigation Practice

The procedures employed in any subsurface exploration program are dependent upon a variety of factors which vary from site to site. The project design objectives and the expected site conditions have a major influence on the subsurface exploration and the development of a drilling plan. The objectives of a drilling plan should be to adequately characterize the subsurface conditions at the site so: a) The Designer can analyze the conditions to formulate a cost effective solution, and b) The Contractor can, in conjunction with any necessary site investigation, prepare a bid which will reflect the work anticipated based on the conditions to be encountered. A secondary objective is to obtain maximum subsurface information from a minimum number of exploratory borings.

The following is a list of requirements for a foundation investigation for State or Federally funded bridge projects developed for funding through the Kansas Department of Transportation.

1. Perform a site specific investigation for all Span Bridge, or Bridge-size Box projects.
2. Make one boring at the centerline of each pier bent and abutment for a bridge or center of structure for RCB/RFB. A probe investigation may be carried out for bridge size boxes if additional geology investigations have been done in the surrounding area of the proposed structure to support this substandard practice. Additional borings should be made as necessary to develop a continuous soils and geology profile through the structure area including the bottom of the channel. When the drilling plan can be supplemented with additional information, one boring at the centerline of each abutment may be considered to meet the minimum requirement. The supplemental information should be considered only if it is documented and directly supports an accurate soils and geology profile. When rock is encountered at a span structure, a MINIMUM of at least one of the required borings will obtain a core of the bedrock. An unconfined compression test should be taken at each change in lithology and at a minimum of every 5 feet of depth. Borings should be advanced at least 5 feet below the recommended foundation element elevations.

(Taking advantage of a substandard “probe” investigation at the site for a proposed bridge-size box will not account for the characteristics of the subsurface material(s). The probe may indicate the presence of rock within the immediate reach of the streambed, but this information may be a false negative, or a false positive. Also, it is not only rock which can cause issues for bridge-size boxes. Soils incapable of supporting load may be present a couple feet below streambed. Utilizing a probe investigation for a proposed structure may result in the wrong type of structure (RCB instead of RFB) being selected for design, it may result in large change orders submitted during construction due to stabilizing unsuitable material or removing and replacing unusable material to construct the box on, or using a probe may result in building a more expensive RFB when an RCB would have performed adequately.)

3. When approach fill embankments of significant height are used at bridge ends founded on compressible material, make at least one boring at the critical location for each embankment location to determine potential problems associated with settlement and stability of the embankment. The

borings for the embankments can usually be combined with the borings made for the abutments of the structure. Address slope stability and settlement issues in the geotechnical report.

4. Obtain sufficient soil and rock samples from all borings to adequately characterize the subsurface materials to a depth appropriate for the loads and the foundation system to be proposed.⁽¹⁾
5. Appropriate sampling should be obtained at five-foot intervals in the soil mantle on at least one of the borings where soil thickness and site conditions warrant. The standard penetration test is the minimum acceptable sampling technique.⁽²⁾ (An incomplete test (50/3", 50/6", etc.) is not an acceptable substitute for testing of cored material. At any point, if there is an incomplete test a core should be taken from that elevation to the bottom of the boring. This is regardless of whether the proposed foundations will be drilled shafts or driven pile).
6. Field documentation of rock units present at the site are to be characterized as to stratigraphy (geologic nomenclature of each unit), lithology (basic type of material), physical condition (weathering, bedding, color, etc.) and engineering properties (jointing, strength, etc.).⁽³⁾
7. Perform sufficient laboratory testing to characterize all subsurface material.⁽⁴⁾
8. Information shown on the boring logs should include the following:
 - a. Depth and type of all samples obtained.
 - b. A visual and textural description of the subsurface material.
 - c. Thickness and geologic nomenclature of each stratum encountered.
 - d. A record of the Standard Penetration Test as well as any other tests that have been run.
 - e. An accurate location and top hole elevation for each boring.
 - f. Stabilized groundwater elevation.
9. When rock is encountered at shallow depths, make additional transverse borings.⁽⁵⁾
10. Furnish a set of office check plans by the Designer to the Geologist and/or Geotechnical Engineer for review of the items related to the geological investigation. Following the review the plans should be returned to the Designer with any necessary comments.
11. Perform the Geotechnical Site Investigations under the supervision of a licensed Geologist or Geotechnical Engineer.
12. For All Foundations; State in the recommendations the Geotechnical Nominal Resistance Calculated, Geotechnical Factored Resistance, Phi factor used, and the governing factor for the design. The units for Pile Foundations should be in KIP. For Drilled Shaft Foundations the Skin Friction Resistance and End Bearing Resistance should both be in KIPS/sq.ft. resistance Spread footings should be KIPS/sq.ft. resistance.

To provide further guidance, the following "Standard Practice" for Soil Foundation Investigations for Bridges is outlined.

If a new embankment will be placed on a soil foundation, an existing embankment will be widened or the grade elevated by 10 feet, an existing bridge shortened by the replacement structure, or if the new structure will be built on an offset alignment; perform the following for a soils foundation investigation:

1. If the depth to bedrock is 10 feet or more, obtain undisturbed soil samples at 5 foot intervals throughout the soils profile on at least one abutment location. If the soils (depths, types) vary between the two abutments, perform a similar sampling strategy at the second abutment.
2. Perform consolidation testing on each recovered sample below the water table. As a minimum, perform unconfined compression testing on each recovered sample.
3. Perform slope stability analysis of the proposed configuration. If the safety factors are questionable, perform more advanced strength testing.
4. Perform a settlement analysis including amount of settlement anticipated and the time frame for the settlement to occur.
5. Author an LRFD Geology report detailing findings of the investigation complete with recommendations. A sample report is in the Appendix.

Possible ASTM Standard Tests (varies by site characteristics): D1586, D2936, D 2938, D3740, D5434, D5549, D5607, D6032. This is not an exhaustive list of tests required to create a quality Geology Report for the bridge site(s), but it does cover many of the basics.

Footnotes:

- (1) Soil and rock strengths are needed for the Engineer to calculate bearing capacities for various foundation elements.
- (2) This test should be performed only in non-cohesive soils. Correlations in cohesive soils are discouraged unless considerable data exists to justify the results.
- (3) This is necessary so the Engineer knows what conditions were found in the borings and can apply his knowledge and experience with identified members to adequately perform an analysis. Further, this information allows contractors who are familiar with geologic members and know how they can be excavated to submit an accurate bid.
- (4) Laboratory testing of material obtained from borehole samples is needed for the Designer to perform an engineering analysis which is the basis for recommendations. For example, on any foundation that relies on end bearing (e.g., a spread footing or drilled shaft), an unconfined compression test of the material on which the foundation will be bearing is considered the minimum testing that should be performed.
- (5) Bedrock encountered at shallow depths may in fact be a "floater" and not a continuous formation of rock. If the bedrock encountered is a "floater" then the amount of rock excavation will be incorrectly identified and further the geology of the site will be misrepresented.

- (6) The Engineer should know what material lies below the foundation element to ensure that the foundation element is on competent material. Therefore the boring should extend a minimum of 5' below the bottom of the proposed foundation element. It's also necessary so minor deviations in the excavation limits can be compensated without additional cost.

17.6 Geology Report Information

LRFD Geology incorporates a variety of resistance factors to arrive at a "Maximum Resistance" for drilled shaft, spread footing, or pile foundations.

The "Pile Damage" resistance factor (ϕ_c) (H-pile) of 0.6 (without pile points/tips) or 0.5 (when pile points/tips are used) is applied to calculate the maximum structural resistance of the steel pile (AASHTO 6.5.4.2). HP10x42 with an area of 12.4 sq. in. and a yield stress of 50 ksi will have a maximum structural resistance of 372 kips if pile tips are not used and 310 kips if tips are used. This is the maximum structural capacity of the steel pile.

The geologic layer also receives a bearing resistance factor (ϕ_{dyn}) ranging from 0.10 to 0.80 (AASHTO Table 10.5.5.2.3-1). 0.10 is the resistance factor to be used if the ENR formula is used without any dynamic or static testing on the piles and no field verification of hammer performance. 0.80 can be used with dynamic testing performed on 100% of production piles along with a static load test for each site condition. 0.55-0.65 is typically used if PDA testing is performed on a minimum of 2 piles (current AASHTO specification) at the site then driving criteria is established using the PDA results and the rest of the pile are driven to that criteria using the modified ENR formulas given in the KDOT Specifications. There is also a table for resistance factors (ϕ_{stat}) (AASHTO Table 10.5.5.2.3-2). One "Resistance Determination Method" titled "End Bearing in Rock – Canadian Geotech. Society, 1985" allows a resistance factor of 0.45. This value has been commonly used if no dynamic testing will be performed on site. Whether the geologic capacity has actually been determined from this method is uncertain.

Using the maximum resistance factor of 0.65 for dynamic testing, the above capacities are reduced to 242 kips and 202 kips, respectively. The factored nominal resistance for an HP 10x42 pile should not be higher than 121 tons or 101 tons in most geology reports depending on whether pile points are recommended or not. To achieve a higher phi for dynamic testing is cost-prohibitive for an LPA project.

Driving stresses are limited in steel pile to 0.9 times the yield strength of the steel. In most situations 50ksi steel is supplied for steel pile. This equates to a driving capacity of 558 kip, or 279 ton for HP10x42 pile. This does not typically limit the final capacity of the pile due to the damage factor, and bearing resistance factor, but needs to be monitored in circumstances where pile are driven through thick layers of stiff clay, or through thin layers of shale or bedrock in order to get to a layer of geology which will support the loads of the structure.

The term "practical refusal" should not appear in any geology report concerning bridge foundations. The factored nominal resistance of the foundation element should be called out. The capacity of the geologic

member should be clearly stated on the borehole report/table. The engineer will specify what Strength 1 design load the foundations must support and determine the size and arrangement of the foundation elements to use based upon the factored nominal resistance clearly labeled for various pile sizes in the report.

Appendix

Plan Review Summary Information									
Information	Plan Type	# of Plan Copies	Lead Time Required	Specs to Review	Note Numbers to Review		P.E. Stamp Required	Plan Review	Recommend Approval
Shop Details	Consultant	*	Project Specific	101 106 705 707 709 716 719 721 722 733	5200 6000 6010 6100 6110 6111 6115	6200 6210 6220 6410 6420 6600 6620	No	No	* *
	In House	*	Project Specific	1609	6120 6130	6625 7410	No	Yes	* *
Shoring	Standard	*	3 weeks	701	30 35		Yes	Yes	Yes
	Railroad		6 weeks	702	300 1030				
Falsework	Category (1)	*	4 weeks	105 708 710	4100 4105 4115 4120	4130 4140 7800 7810	Yes	Yes	Yes
	Category (2)	*	4 weeks	105 708 710	4100 4106 4110 4120	4130 4140 7800 7820	Yes	District Policy	
Erection	Category A	(1)		105 708	3000 3010	6521 6522 6523	No	No	No
	Category B	*	4 weeks	710	5210 6420	8700	Yes	Yes	Yes
	Category C	*	4 weeks	SP07-07004	6520		Yes	Yes	Yes
Demolition	Category A	(1)		105 708	3000 3010	6521 8700	No	No	No
	Category B	*	4 weeks	710	5210 6420	9001 9002	No	No	No
	Category C	*	4 weeks	SP07-07014	6520	9003	Yes	Yes	Yes
Pour Sequence	Discuss Possible Changes at Precon Meeting	*	2 Weeks	105 708 SP07-0711	4140 4200 5100 5110 7000 7210 7215	7300 7301 7310 7311 7312 7320 7330 7400	No	Yes	Yes

Based on project complexity, the specifications and the notes listed in this document may only be the base of what is required.

* Electronic submittal conforming to 105.10 (b) of the Standard Specifications for State Road and Bridge Construction

* * General Compliance Stamp

Typical Geology Report Foundation Recommendations

Abutment and Pier Foundations

We recommend pile foundations for the abutments and piers for these bridges. Elevations are given for 10x42, 12x53, and 12x74 H-piling. The pile will penetrate the mantle and achieve the required resistance within the underlying weathered shale and sandstone of the Stranger Formation. The designed resistance is governed by the drivability of the pile. A Phi factor of 0.60 is given based on the geologic investigation performed and knowledge of the site.

The following table gives the top of bedrock elevation for the Stranger Formation and the maximum anticipated pile tip elevation at each abutment and pier. If piling achieves bearing at a higher elevation, further driving should cease to avoid damage to the pile. Caution must be exercised not to overdrive the piling resulting in damage to the H-pile

*Road Over Unnamed Creek (D)
Br. No. 000000000000001*

Location	Centerline Station	Bedrock Elevation	H Pile HP 10x42 Elevation	H Pile HP 12x53 Elevation	H Pile HP 12x74 Elevation
Abutment 1	700+93.67	765.4	760.4	760.4	760.4
Pier 1	701+41.27	769.8	764.8	764.8	764.8
Pier 2	702+04.75	764.0	759.0	759.0	759.0
Abutment 2	702+52.35	765.2	760.2	760.2	760.2

*Road Over Unnamed Creek (D)
Br. No. 000000000000001*

Location	Centerline Station	Bedrock Elevation	H Pile HP 10x42 Elevation	H Pile HP 12x53 Elevation	H Pile HP 12x74 Elevation
Abutment 1	701+05	765.4	762.0	761.0	760.0
Pier 1	701+47	764.8	761.5	760.5	759.5
Pier 2	702+03	763.8	762.0	761.0	760.0
Abutment 2	702+45	764.0	762.2	761.2	760.2

LRFD Design

Resistance and Phi Factor Information

	Pile HP 10x42	Pile HP-12x53	Pile HP-12x74
Rn (kips)	372	465	654
Rr (kips)	223	279	392.4
Phi Factor	0.60	0.60	0.60

(This Page Intentionally Left Blank)